
Tieback Wall Design and Construction

Final Report
to the
Alabama Highway Research Center

Frazier Parker, Jr., Director

Dr. David J. Elton, P.E.
James E. Whitbeck

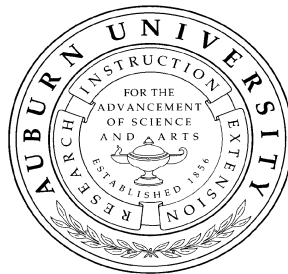


Table of Contents

LIST OF FIGURES	IV
LIST OF TABLES	VI
1 INTRODUCTION.....	1
1.1 Overview of Report	1
1.2 Anchors.....	1
1.2.1 History.....	1
1.2.2 Basic Description	1
1.2.3 List of Terms	2
1.2.4 Advantages and Disadvantages	2
1.2.5 Applications.....	3
1.2.5.1 Temporary Anchors.....	3
1.2.5.2 Permanent Anchors.....	4
1.2.6 Alternatives	4
1.3 Wall Facings.....	4
2 TIEBACKS.....	8
2.1 Design Considerations.....	8
2.1.1 Site Investigation.....	8
2.1.1.1 General Considerations.....	8
2.1.1.2 Rock.....	9
2.1.1.3 Soil.....	9
2.1.1.4 Groundwater	9
2.1.2 Geotechnical Stability.....	9
2.1.2.1 Introduction to Earth Pressures.....	10
2.1.2.1.1 Lateral Earth Pressure.....	10
2.1.2.1.2 Apparent Earth Pressure Diagrams.....	10
2.1.2.1.3 Apparent Earth Pressures.....	14
2.1.2.1.3.1 Sand	14
2.1.2.1.3.2 Soft to Medium Clay	14
2.1.2.1.3.3 Stiff Clay.....	14
2.1.2.2 Factors of Safety.....	16
2.1.2.2.1 Factor of Safety with Respect to Strength	16
2.1.2.2.2 Factor of Safety with Respect to Load	16
2.1.2.2.3 Backcalculated Factors of Safety.....	18
2.1.2.2.3.1 Sand	18
2.1.2.2.3.2 Soft to Medium Clay	18
2.1.2.2.3.3 Stiff Clay	19
2.1.2.3 Limit Equilibrium Anchor Force Design Procedure.....	19
2.1.2.3.1 Introduction	19

2.1.2.3.2 Failure Plane Location	20
2.1.2.3.3 Simple Failure Surface Analysis.....	20
2.1.2.3.4 Using Limit Equilibrium for Design.....	25
2.1.2.3.4.1 Internal Stability	25
2.1.2.3.4.2 Global Stability.....	25
2.1.2.3.4.3 Intermediate Stability.....	29
2.1.3 Anchor Characteristics	29
2.1.3.1 Types of Anchors	29
2.1.3.2 Tendons	32
2.1.3.2.1 Types	32
2.1.3.2.2 Design.....	32
2.1.3.2.2.1 Design Criteria.....	32
2.1.3.2.2.2 Design for Stress.....	33
2.1.3.2.3 Corrosion Resistance of Unbonded Tendons	33
2.1.3.2.3.2 Protection Methods.....	34
2.1.3.3 Grout.....	35
2.1.3.3.1 Functions	35
2.1.3.3.2 Composition.....	35
2.1.3.3.3 Design.....	36
2.1.3.3.3.1 Grout-Ground Bond Design	36
2.1.3.3.3.2 Grout-Tendon Bond Design	37
2.1.3.3.4.2 Corrosion of Tendon by Grout	37
2.1.3.4 Anchor Head.....	38
2.1.3.4.1 Introduction	38
2.1.3.4.2 Corrosion Protection.....	38
2.1.4 Number, Spacing, and Orientation of Anchors.....	42
2.1.4.1 Horizontal and Vertical Spacing and Number.....	42
2.1.4.2 Orientation	43
2.1.5 Shear and Moments in Wall	43
2.1.6 Drainage	43
2.1.6.1 Need for Drainage	43
2.1.6.2 Common Drainage Methods.....	43
2.2 Installation	45
2.2.1 Anchors	45
2.2.1.1 Drilling	46
2.2.1.1.1 Drilling Methods.....	46
2.2.1.1.2 Flushing	47
2.2.1.1.3 Water Testing of Borehole	49
2.2.1.2 Tendon.....	50
2.2.1.2.1 Storage and Handling	50
2.2.1.2.2 Installation	50
2.2.1.3 Grout.....	52
2.2.1.4 Construction Limitations	53
2.2.1.5 Stressing	53
2.2.1.5.1 Methods	53

2.2.1.5.2 Load Monitoring.....	55
2.2.1.6 Prooftesting.....	55
2.2.1.6.1 Stressing Forces.....	57
2.2.1.6.2 Precontract Tests.....	57
2.2.1.6.3 On-Site Suitability Tests.....	58
2.2.1.6.4 Acceptance (Proof) Tests.....	58
2.2.1.6.5 Creep.....	58
2.2.1.6.6 Testing Program	58
2.2.2 Wall Facing Installation Concerns.....	59
2.3 Monitoring	59
2.3.1 Anchors	60
2.3.1.1 Load Monitoring.....	60
2.3.1.2 Pore Water Pressure	63
2.3.1.3 Earth Pressures	63
2.3.2 Wall Facing	64
2.3.2.1 Corrosion	64
2.3.2.2 Drainage	64
2.3.2.3 Erosion at the Toe.....	64
2.3.2.4 Movement of the Wall.....	64
2.3.2.4.1 On-site Methods	64
2.3.2.4.2 Remote Methods.....	65
3 GEOLOGY OF BIRMINGHAM, AL.....	66
3.1 General Considerations.....	66
3.2 Site Conditions	66
3.2.1 Flooding.....	66
3.2.2 Soil and Rock Characteristics	66
3.2.3 Earthquakes and Sinkholes.....	67
3.3 Rock Formations in Birmingham	67
3.3.1 Knox Group Undifferentiated.....	67
3.3.2 Ketona Dolomite.....	68
REFERENCES.....	69
BIBLIOGRAPHY.....	70
ASTM SPECIFICATIONS FOR STEEL TENDONS.....	72

List of Figures

Figure 1. Typical parts of a ground anchor (from Xanthakos 1991).....	2
Figure 2. Wall types (from Xanthakos 1994).....	6
Figure 3. Typical construction sequence for a slurry wall (from Xanthakos 1994).....	7
Figure 4. Apparent earth pressure (from Schnabel Foundation Company 1996).....	11
Figure 5. Variation in measured lateral earth pressures in braced excavations (from Terzaghi and Peck 1967)	12
Figure 6. Schnabel's apparent earth pressure diagram (from Schnabel Foundation Company 1996).....	13
Figure 7. Failure pattern assumed for Henkel's method (from Schnabel Foundation Company 1996) ...	15
Figure 8. Failure surface used in limit equilibrium analyses of anchored walls (from Schnabel..... Foundation Company 1996)	17
Figure 9. Force equilibrium consideration for an anchored wall system (from Schnabel..... Foundation Company 1996)	21
Figure 10. Comparison of method for determining minimum unbonded length, horizontal backfill (from Schnabel Foundation Company 1996)	22
Figure 11. Comparison of method for determining minimum unbonded length, sloping backfill..... (from Schnabel Foundation Company 1996)	23
Figure 12. Force equilibrium considerations for anchored wall systems, failure surface in front of bonded length (from Schnabel Foundation Company 1996)	24
Figure 13. Active and passive earth pressure coefficients (from Navy 1982).....	26
Figure 14. Force equilibrium considerations for anchored wall systems, failure surface behind the anchor (from Schnabel Foundation Company 1996)	27
Figure 15. Definition of non-dimensional parameters Π , δ and γ (from Schnabel..... Foundation Company 1996)	28
Figure 16. Requirements for anchor load along the anchor length (base failure) (from Schnabel..... Foundation Company 1996)	30
Figure 17. Types of ground anchors (from Hanna 1982).....	31
Figure 18. Tendon tieoff details (from Hanna 1982).....	39
Figure 19. Recommended tolerances at anchor head (from Xanthakos 1994).....	40

Figure 20. Typical anchor head detail for double protection of strand tendon (from Littlejohn 1986)	41
Figure 21. Drainage schemes for retaining walls (from Bowles 1988).....	44
Figure 22. Tendon centralizer details (from Xanthakos 1994).....	51
Figure 23. Anchor stressing details (from Hanna 1982)	54
Figure 24. Anchor stressing log (from Hanna 1982).....	56
Figure 25. Schematic view of load disc cell (from Hanna 1973)	61
Figure 26. Monitoring systems for wall (from Xanthakos 1994).....	62

List of Tables

Table 1. Soil filter criteria (from Terzaghi and Peck 1967).....	45
Table 2. Choice of drilling method and machinery to fit pertinent conditions	48
Table 3. Drilling rate index for various rocks (from Xanthakos 1991)	49

Tieback Wall Design and Construction

1 Introduction

1.1 Overview of Report

This report gives a general overall introduction to ground anchors, also called tiebacks. Specifically, it focuses on anchors which support retaining walls by use of tendons.

First, a section is devoted to an introduction to anchors and wall facings. The anchor introduction (Section 1.2) includes a general description of anchors with important terms, advantages and disadvantages, applications of anchors, and alternatives. Wall facings typically used with tiebacks are briefly described in Section 1.3 and advantages and disadvantages of each are discussed.

Section 2 is a detailed treatment of tiebacks. Design considerations (Section 2.1) includes discussion of site investigations, a detailed method for determining expected force in a tieback, anchor characteristics, the number and spacing of anchors, and drainage considerations. Also in this section are notes on installation and monitoring of anchored walls.

The geology of Birmingham, Alabama, is treated in Section 3. General geological considerations and site conditions and rock formations of the greater Birmingham area are discussed as related to tieback walls. The report concludes with the references and a bibliography.

1.2 Anchors

This section includes a brief history of the development of anchors, a description of an anchored system, and a list of terms which are often encountered when discussing tiebacks.

1.2.1 History

The history of anchors may be traced back to the late 1800's. In 1847, Frazer described tests on rod anchors which were installed to support a canal bank. Documentation of the use of screw piles to prevent flotation of floor slabs was described in 1900. However, the Cheurfas dam in Algeria represented the first major application of ground anchors. In 1934, Coyne applied 1000-ton capacity anchors at 3.5 m (11.5 ft) intervals to stabilize the foundation. After this success and the advent of high-strength steel and improved grouting techniques, ground anchors grew in popularity in several countries in Europe and eventually in the United States (Xanthakos 1991).

1.2.2 Basic Description

Tiebacks (also called ground anchors or simply anchors) are devices used to support retaining walls. A rod, wire, or tendon (cable) is anchored to the ground at one end and to the wall at the other. Anchoring in the ground is typically achieved by boring a hole in the soil or rock and encasing a portion of the wire or rod in a grout mixture. The grout forms a bond with the surrounding soil and tieback and secures the anchor. If a tendon is used, the wire is usually prestressed to a desired tension by hydraulic jacks. The tendon may be inclined at any angle. Design and installation of tiebacks requires specialized methods and equipment and post-installation monitoring.

Figure 1 depicts a typical ground anchor and its components. Individual components will be defined briefly in the following section and more completely in Design Considerations (Section 2.1).

1.2.3 List of Terms

A few important terms which are common in discussions of tiebacks are discussed here (Figure 1).

1. The *anchor head* secures the anchor to the retaining wall and is the location of a jack attachment for prestressing operations. It consists of a mechanism to secure the tendon and a *bearing plate* to distribute the load to the retaining wall.
2. The *anchor tendon* is a structure, usually a rod, wire, or cable, which connects the anchor head to the grouted portion of the anchor.
3. The section of tendon which is embedded in the grout is known as the *fixed length*, while the tendon located between the anchor head and the grout is the *free length*.
4. *Permanent anchors* are designed for a life of more than two years, while a *temporary anchor* is in use for less than two years.
5. A *prestressed anchor* is the most common type and is tensioned at installation and remains under tension throughout its life. A *non-prestressed anchor* (also called a dead anchor) is not prestressed at installation.
6. The *working load* is the force which the anchor will maintain throughout its life. The *test load* is applied soon after installation to confirm the anchor's integrity, and the *lift-off load* is the load required to lift the bearing plate from the wall.

1.2.4 Advantages and Disadvantages

This section provides guidance regarding when tiebacks should or perhaps should not be used.

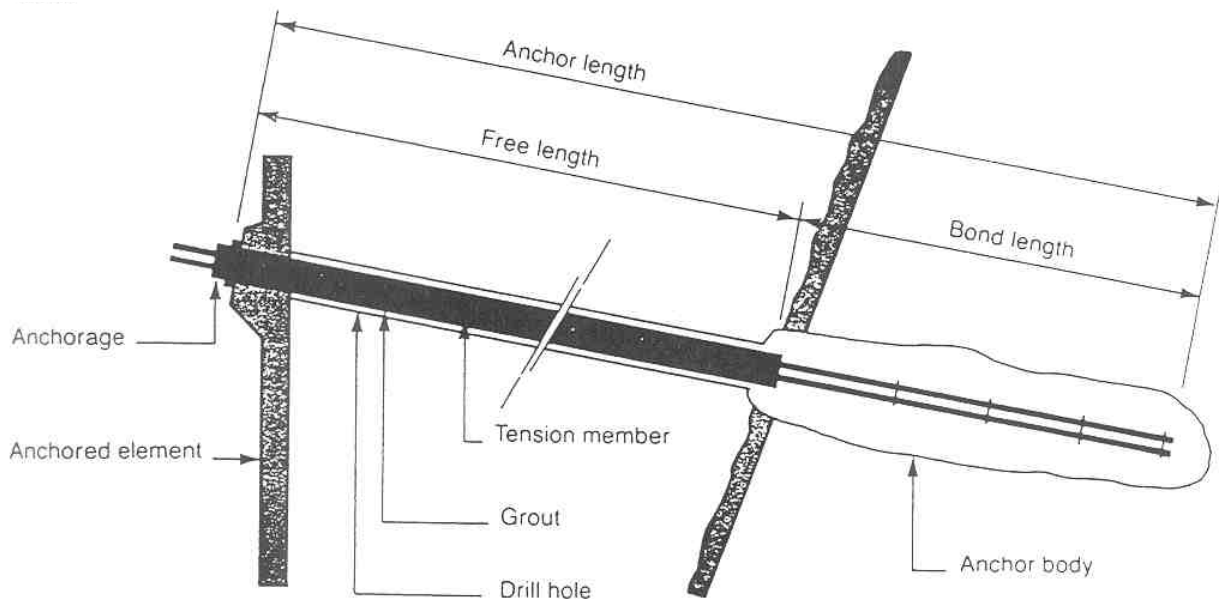


Figure 1. Typical parts of a ground anchor (from Xanthakos 1991)

Advantages of anchored systems for cut slope retaining structures include: (Winterkorn 1991):

1. Incorporation of the temporary excavation support system in the permanent facility.
2. Reduction in the amount of excavation and the concrete work required for footings.
3. Elimination of backfilling behind the wall.
4. Elimination of foundation piles to support the wall structure in mountainous areas with unstable slopes or sites underlain by compressible soils.
5. Reduction in quantities of reinforced concrete required for the construction of the retaining wall.
6. Reduction in construction disturbance and right-of-way acquisition, which, in urban sites, may eliminate the need for underpinning nearby structures.
7. Adaptability to different site conditions and soil profiles, allowing for cost-effective use in repair and reconstruction of existing structures.

Tiebacks offer other advantages. One is the ability to support a temporary construction excavation without the need for cumbersome bracing that obstructs workspace. Anchors may be proof tested to guarantee their capacity. Tiebacks are cheaper than conventional bracing in cuts of more than 4.6 to 6.1 m (15 to 20 ft) and/or widths of greater than 18.3 m (60 ft), and construction is not impeded by cross-bracing. Finally, there is an increase in public safety since less construction area is required (PileBuck 1990).

Despite these advantages, anchors are not the solution for all situations. Some disadvantages include (Winterkorn 1991):

1. Permanent underground easements are required.
2. In fine-grained soils, effective groundwater drainage systems may be difficult to construct and to maintain.
3. In plastic clayey soils, creep can significantly affect long-term performance and structure displacements.
4. In soft cohesive soils, pull-out capacity of tiebacks cannot be economically mobilized.
5. Durability considerations may impose severe limitations on the use of metallic inclusions in aggressive, corrosive environments.
6. Nearby construction may change soils stresses, decreasing tieback capacity possibly leading to failure.

Other disadvantages include potentially increased costs over more conventional walls, an uncertainty regarding their performance over time, and a lack of a standard design procedure (PileBuck 1990).

1.2.5 Applications

Applications of tieback walls vary according to whether the wall is temporary or permanent. This section lists some applications of each type of installation.

1.2.5.1 Temporary Anchors

Temporary anchors are almost always used to support excavations at construction sites. Basements are the most common type of construction utilizing anchors.

1.2.5.2 Permanent Anchors

Support of retaining walls are a major use of tiebacks in permanent applications. Although tiebacks are not usually used to support building foundation walls since easements are required from adjacent property owners, there are cases such as a steeply sloping site which make the use of tiebacks attractive. Tiebacks may be used to prevent a landslide or to stabilize soil which has experienced movement. Rock fractures may be stabilized as well. Anchors are often used to support marine structures such as walls at harbors. Finally, tiebacks may be used to repair or alter existing walls and abutments. (PileBuck 1990).

1.2.6 Alternatives

Tiebacks are not always the best solution to a given retaining wall project. This section describes several alternatives to tieback walls.

Perhaps the simplest alternative to tiebacks is to cut the slope back to a less steep angle. One advantage is that this method has been used for many years; therefore, contractors have much experience with the process. The additional material which is removed may be used for fill, and there is no need to acquire a permanent underground right of way. Disadvantages are primarily related to cost. More excavation is needed, and soil/rock must be removed. This method requires more property acquisition at the top of the slope, and this land may not be able to be used for any other purpose.

Soil nailing is another option. Soil nailing is similar to tieback construction. It is used in top down construction. Typically, the nails (rods) are drilled and inserted in the soil with facing. Large bearing plates are used. The nail is often posttensioned. This method may allow for quicker installation and for the installation of a cheaper wall facing. However, the method is not widely used in the United States (although it is popular in Europe). In addition, installation costs may be higher (Bang 1992).

Other options include relocating the project or grouting the slope so it can be cut more steeply.

1.3 Wall Facings

There are numerous types of walls which may be used in anchored systems. This section will discuss some of the most common types and provide some advantages and disadvantages of each.

For walls which involve concrete cast in place below grade, the construction method is "tremie" concrete. This method involves drilling a hole, filling it with a slurry as it is drilled, and then pouring concrete into the hole through a long tube which reaches to the bottom of the hole. The concrete, which is denser than the slurry, displaces the slurry up and out of the hole. Reinforcing may be placed before the tremie process begins or after, although placement in fresh concrete is more difficult.

Anchored inclined retaining walls consist of a simple slab of reinforced concrete supported by anchors. These slabs, precast or cast in place, which vary in thickness from 0.3 m (1 ft) to 0.6 m (2 ft) or greater, offer excellent flexural rigidity and stiffness and may be designed as a two-way member. No embedment is necessary below ground level, there are no constraints on the number or placement of anchors, and little axial load is applied downward. Precast holes may be used to install the tiebacks. Good quality may be obtained even under field conditions (Figure 2a).

Cylinder walls are composed of large holes drilled closely together and then filled with concrete. Construction of the drilled shafts proceeds by first installing every other shaft, then repeating the process on every other shaft, often staggered behind the first row.

H-piles may be driven in with lagging (wood or concrete) added behind the flanges of the H-piles as excavation proceeds to create a *steel soldier pile and lagging wall* (Figure 2d). These walls offer moderate bending resistance and fair watertightness if care is used in construction. Disadvantages include rusting of the steel piles and the possibility that the ground will be hard or contain boulders which precludes pile driving. A steel soldier pile and lagging wall is typically used for temporary installations. Spacing of anchors is usually chosen to match beam and lagging spacing which is typically 2.4 to 3 m (8 to 10 ft).

A similar type of wall is formed by *soldier piles embedded in concrete*. Steel H-piles or concrete piles are driven in as in the previous wall type, and one space at a time is excavated between the piles and filled with concrete. Drilled shafts may be used instead of piles, and reinforcement may be installed in the shafts. Features of the wall include moderate bending resistance and good watertightness. However, the piles are subject to rust, and the ground must allow the piles to be driven in.

Closely spaced piles of any type (pipe piles work well) may be used to construct what is typically a temporary wall. Moderate bending resistance is available depending upon the pile material. Ground conditions must be suitable to driving of the piles, and watertightness is poor. As with all walls which contain driven piles, work in congested areas may be limited by available headroom and by noise concerns. The tiebacks are typically attached to a waler that runs horizontally across the piles.

Steel sheetpiling offers low bending resistance and fair watertightness if good construction practices are used (Figure 2e). However, rusting of the steel may be a problem, and the soil must be conducive to driving of piles. Limited vertical load capability may limit anchor inclination, but horizontal anchor spacing is not limited since horizontal waling beams (walers) must be installed across entire wall face. to distribute the tieback force across the face of the thin wall.

Concrete sheetpiling offers the same advantages and disadvantages as steel sheetpiling except for rusting. However, there is the additional disadvantage that cracks may be introduced in the concrete during installation if care is not taken.

Diaphragm walls, also called "slurry walls," are formed when concrete is cast into a long slot in the ground (Figure 2 b,c). The slot may be created by excavating one long trench with a special machine and using slurry to keep the trench open, by driving piles into the ground and excavating the panels between them, or by a large machine that augers out the soil and pumps in slurry. Alternatively, the wall sections may be precast, assembled on site, and installed in the trench. These walls offer very good bending resistance and a very good watertightness. Also, they offer excellent vertical load capacity and impose no limitations on anchor spacing or inclination. Figure 3 shows a typical construction sequence for slurry walls.

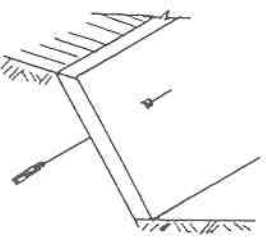
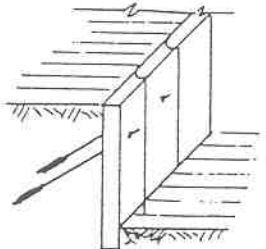
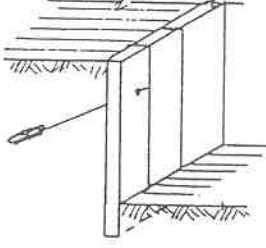
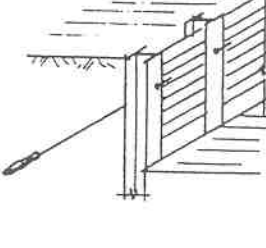
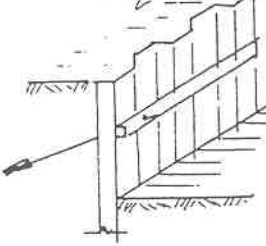
 <p>(a)</p>	<p>Anchored inclined retaining walls</p> <p>Built of reinforced concrete. Continuous across joints Variable thickness, ranging from 1 to 2 ft or greater Good quality under field control conditions Considerable stiffness and flexural rigidity Can be designed as two-way slab No embedment necessary below base level Axial downward loads relatively small No restraint on anchor spacing, load, or inclination</p>
 <p>(b)</p>	<p>Cast-in-place diaphragm walls</p> <p>Built of reinforced concrete, usually discontinuous panels Thickness up to 3 ft or greater Good quality under field control conditions Considerable stiffness and flexural rigidity Embedment necessary below base level High capacity in vertical loads Usually 2 anchors per horizontal row each panel No restraint on anchor load and inclination</p>
 <p>(c)</p>	<p>Precast diaphragm walls</p> <p>Factory-built reinforced concrete panels Usual thickness 18–24 in Adequate stiffness and flexural rigidity Embedment necessary below base level Adequate capacity in vertical loads Usually 2 anchors per horizontal row each panel No restraint on anchor load and inclination</p>
 <p>(d)</p>	<p>Soldier piles with lagging</p> <p>Predriven steel beams with lagging; occasionally placed in boreholes Relatively flexible; beam embedment necessary Wall is not watertight Limited capacity in vertical loads restricting anchor force and inclination; anchor spacing to conform to beam spacing and commercial lagging size, usually 8–10 ft</p>
 <p>(e)</p>	<p>Sheet pile wall</p> <p>Driven in suitable ground; generally adequate groundwater control; restricted to soft soils Very flexible wall with limited stiffness Limited capacity in vertical load restricting anchor force and inclination Waling beam necessary at each horizontal anchor row Horizontal anchor spacing not restricted</p>

Figure 2. Wall types (from Xanthakos 1994)

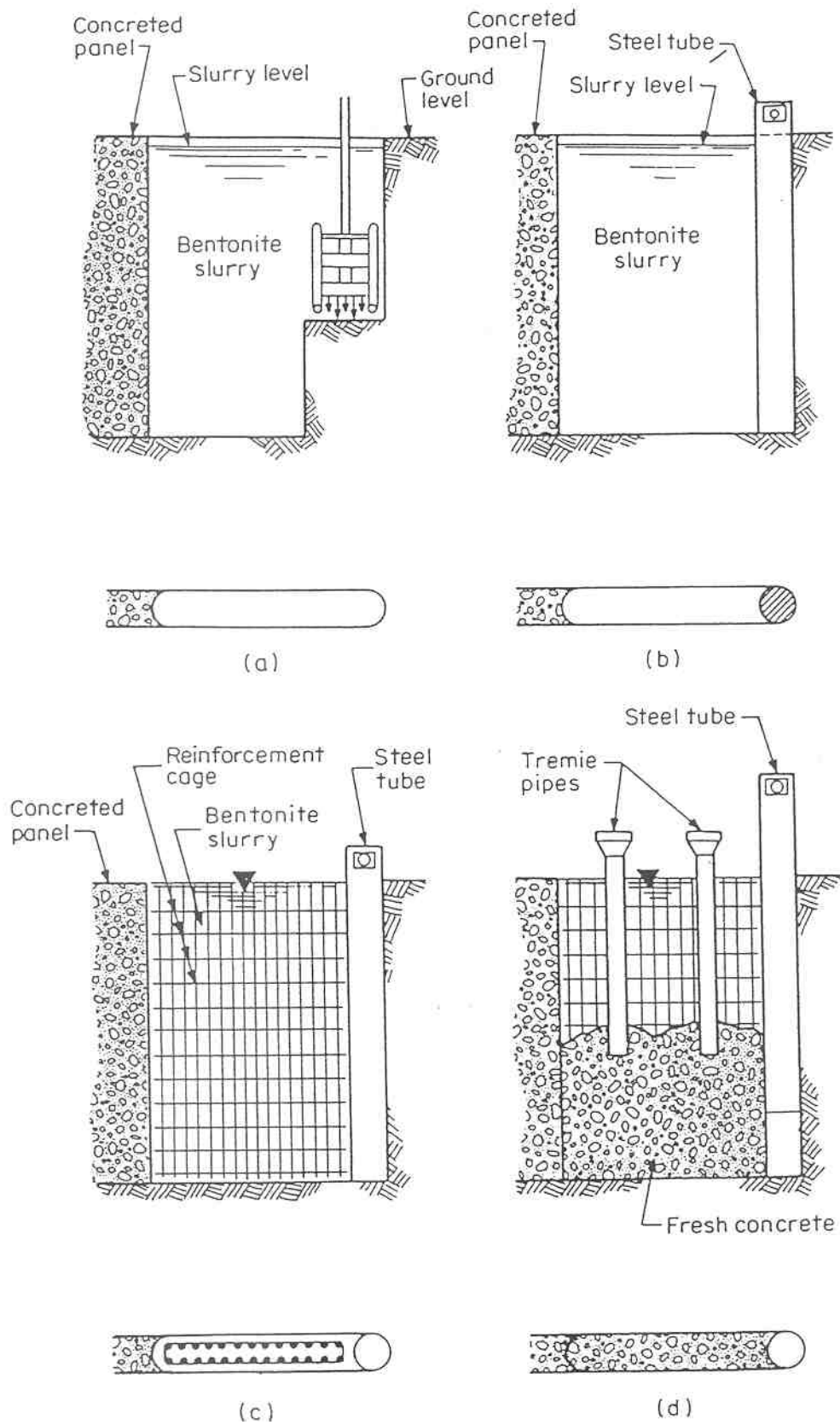


Figure 3. Typical construction sequence for a slurry wall (from Xanthakos 1994)

2 Tiebacks

2.1 Design Considerations

2.1.1 Site Investigation

A thorough investigation of a proposed site for the use of anchors is crucial to the success of the project. Data gathered from the site investigation will be used to determine the placement of anchors, their capacity, materials to be used, corrosion protection required, and the method of installation.

Since every construction site has different ground conditions even at the same site, specific site investigation programs must be determined by an engineer. In addition, the scope of the construction project itself will play a role in determining the site investigation program. This section provides some general considerations with regard to site investigations, and particular considerations for investigating rock, soil, and groundwater.

2.1.1.1 General Considerations

Throughout the planning of a site exploration, the engineer should be aware of several key factors in the design of anchors. These include the behavior of anchors under load, construction methods and the disturbance they may cause to the ground, variation of ground conditions, effects of construction on surrounding property, and environmental concerns such as freezing. Three basic principles of investigation should be kept in mind: scope of the project, accessibility of the ground where the anchors will be formed, and behavior of soil and/or rock under the intense stress that an anchor produces (Hanna 1982).

The initial step in a site investigation is usually known as a "desk study." Readily available information such as maps are studied to determine if further investigation is warranted or if the project is not feasible. Maps and photographs of a proposed site provide information regarding site topography. Geologic and soil survey maps may be used to predict the type of soil and rock which may be encountered and may provide clues to earthquake probability. Information regarding groundwater may be obtained from simple tests. Finally, history of previous construction projects may be used as a guide if such information is available.

An important component of the site investigation is to determine if any of the anchors will be placed on adjoining property. If this is the case, permissions must be obtained from the landowners. Also, the location of underground utilities, foundations, and other structures must be determined, and the feasibility of construction with regard to disturbances to local traffic and surrounding buildings must be studied.

Rock, soil, and groundwater investigations, the topics of the next three sections, are usually carried out by drilling exploratory holes at the site. Since many anchors are installed horizontally while most boreholes are drilled vertically, more boreholes will be required for horizontal anchors than for vertical ones. In addition, anchors are very sensitive to variations in local ground conditions. Other conditions which may lead to the need for more boreholes include sloping ground or very long anchors.

2.1.1.2 Rock

The best investigation method for rock is drilling cores. The rock samples may be analyzed in a lab for composition, unit weight, strength, adhesion to grout, and coefficient of friction with steel (Hobst 1983) as well as modulus of elasticity, uniaxial compressive strength, interfaces between strata, and the amount and condition of water in the rock (Xanthakos 1991). Corings provide valuable data regarding the stratification of rock layers, the structural integrity of the rock (faults, fissures, failure planes), and strength of the rock. Boreholes may be pressure tested to detect the presence of faults and as a guide for grout design.

Rock should be sampled with continuous core recovery methods which require a core not less than 75 mm (3 in) in diameter. Very weak rock may be investigated with a SPT to gain a relative idea of the in situ quality. For soft rock, durability studies should be made. Rock should be graded according to a standard index such as Rock Quality Designator.

2.1.1.3 Soil

Soil investigations should attempt to determine the composition and mechanical properties of the soil as well as the variation of these properties throughout the construction site. Soil samples are gathered for lab analysis which should include composition, shear strength, cohesion, particle size, liquid and plastic limits, and angle of internal friction. Boreholes may be used for determination of the soil limit stress and for groutability tests. In addition, the construction of the testing boreholes may provide an indication of how easily the anchor boreholes may be constructed.

Samples may be obtained using any of a number of standard tools such as the Standard Penetration Test (ASTM D1586-84) and Shelby tubes. Samples should be collected at vertical intervals of about 1.5 m (5 ft) (Xanthakos 1991) or wherever a change in soil conditions is suspected. The CPT or SPT may be used to gather soil density data. A field vane or Dutch Cone may be used in cohesive soil to gauge soil strength.

2.1.1.4 Groundwater

Groundwater levels should be monitored over the long term. Samples of groundwater should be tested for possible corrosive effects on tendon steel and/or grout. Levels should be monitored to determine corrosion protection required, effect of groundwater on soil properties, and hydrostatic forces which may act upon the retaining wall. The best method is by the use of piezometers. Water infiltration may be estimated during construction from a comparison of the amount of drilling fluid pumped into a borehole to the amount which flows out or by field permeability tests. Also, detailed data should be gathered during construction of anchor boreholes in regard to drilling rate and difficulty and condition of the drill spoil.

2.1.2 Geotechnical Stability

The first step in designing ground anchors is determining the force that will be applied to the wall by the soil. This section details a procedure for evaluating the horizontal force exerted on a wall by the soil behind it.

2.1.2.1 Introduction to Earth Pressures

The basic concept regarding forces acting on a retaining wall is that of lateral earth pressures. Various methods of estimating these forces have been developed, ranging from simple to complex. This section will provide a brief introduction to these methods as background for the presentation of a design procedure.

2.1.2.1.1 Lateral Earth Pressure

Two primary methods of estimating lateral earth pressure are used today. Coulomb presented a method in 1776 which assumed a planar failure surface and considered friction between the wall and the soil. Rankine's theory of 1857 was based on the condition at which every soil particle is on the verge of failure and neglected wall friction in estimating both the magnitude and direction of the force. Both theories deal with three different conditions defined by the movement of the wall: active, when the wall has moved slightly outward and allows interparticle soil friction forces to develop; passive, when a wall has moved into the soil mass; and at-rest, which occurs when the wall has not moved in either direction.

In both methods, forces are determined by multiplying the vertical pressure (using terms which account for the weight of the soil and the height of the wall) by a coefficient known as the lateral earth pressure coefficient. For a smooth vertical wall with level backfill, both theories yield a similar result for this coefficient for the active and passive cases.

Other theories that assume a log spiral shape for the failure surface have been developed. However, the results are very similar to those of the much simpler Rankine methods for the active case. Therefore, the design method presented in this report will be based on the Rankine method and on apparent earth pressure.

2.1.2.1.2 Apparent Earth Pressure Diagrams

An alternative way of estimating the pressures exerted on a wall by surrounding soils is by the use of apparent earth pressure (AEP) diagrams. Figure 4 shows the apparent earth pressure diagrams for three different types of soils. These apparent earth pressure diagrams were developed based upon field measurements rather than theory. Measurements were made of the forces exerted on struts which were supporting a retaining wall as excavation proceeded. The forces in the struts were then divided by the area of wall which they supported to construct the apparent earth pressure diagram.

These experiments and similar ones have shown that total forces predicted by the Coulomb and Rankine methods are very close to the observed forces. However, the distribution of these forces along the wall is different. The classical methods yield a triangular pressure distribution, with lower stresses near the top of the wall and higher stresses at the bottom. Actual field studies show variations from this (Figure 5).

Schnabel (1996) suggests using one apparent earth pressure diagram for all designs (Figure 6), stating that "Schnabel Foundation Company has successfully used this diagram to design thousands of anchored excavation support systems and anchored walls in sands, clays, and mixed soil profiles."

Given the close results of the simple and more complex methods, the simpler Rankine method of active earth pressures will be used as the baseline for earth pressure design. A simple approach allows a more general formulation of the boundary condition problem. Also, changes in

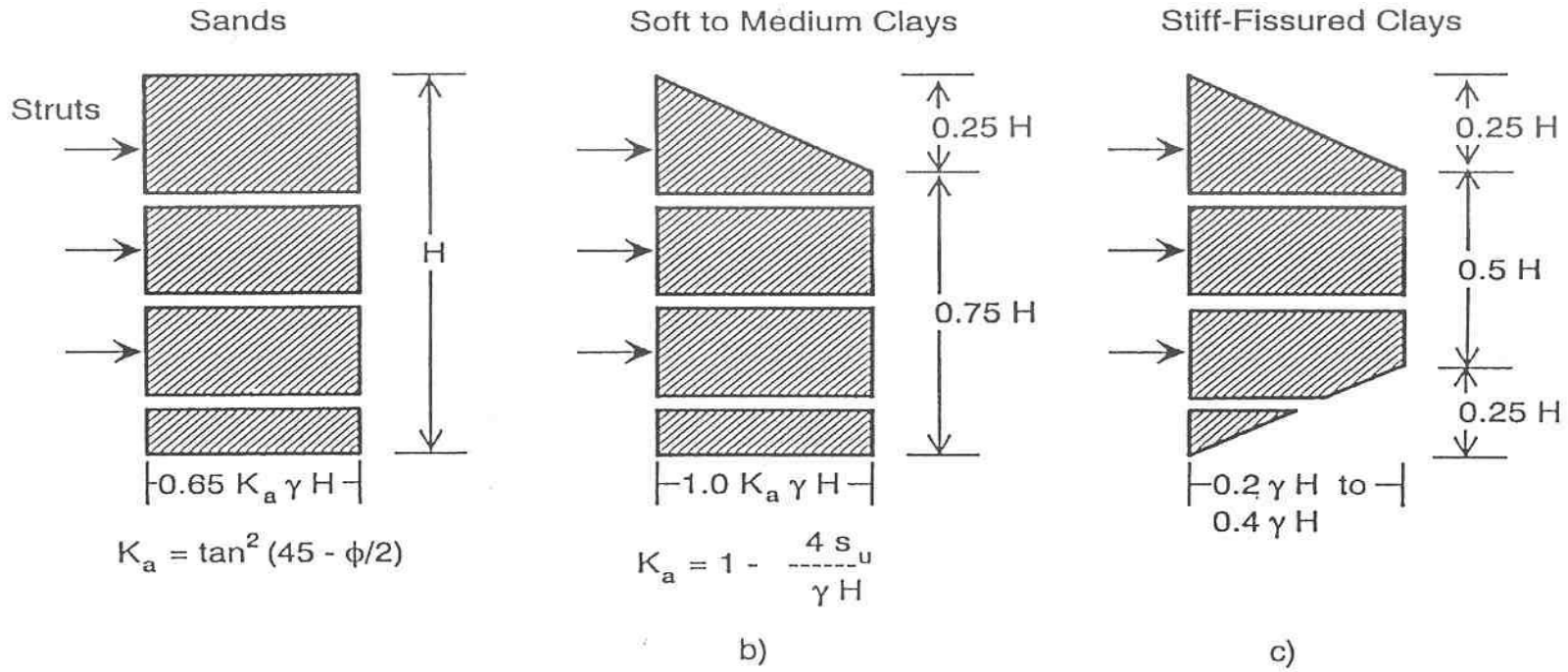


Figure 4. Apparent earth pressure (from Schnabel Foundation Company 1996)

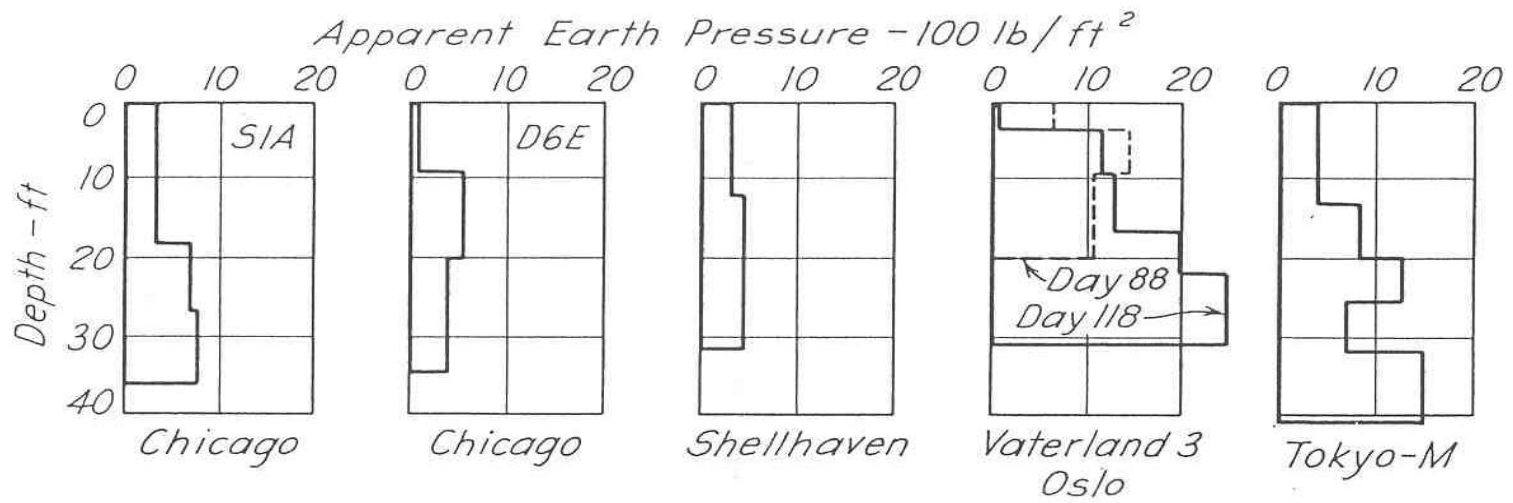


Figure 5. Variation in measured lateral earth pressures in braced excavations (from Terzaghi and Peck 1967)

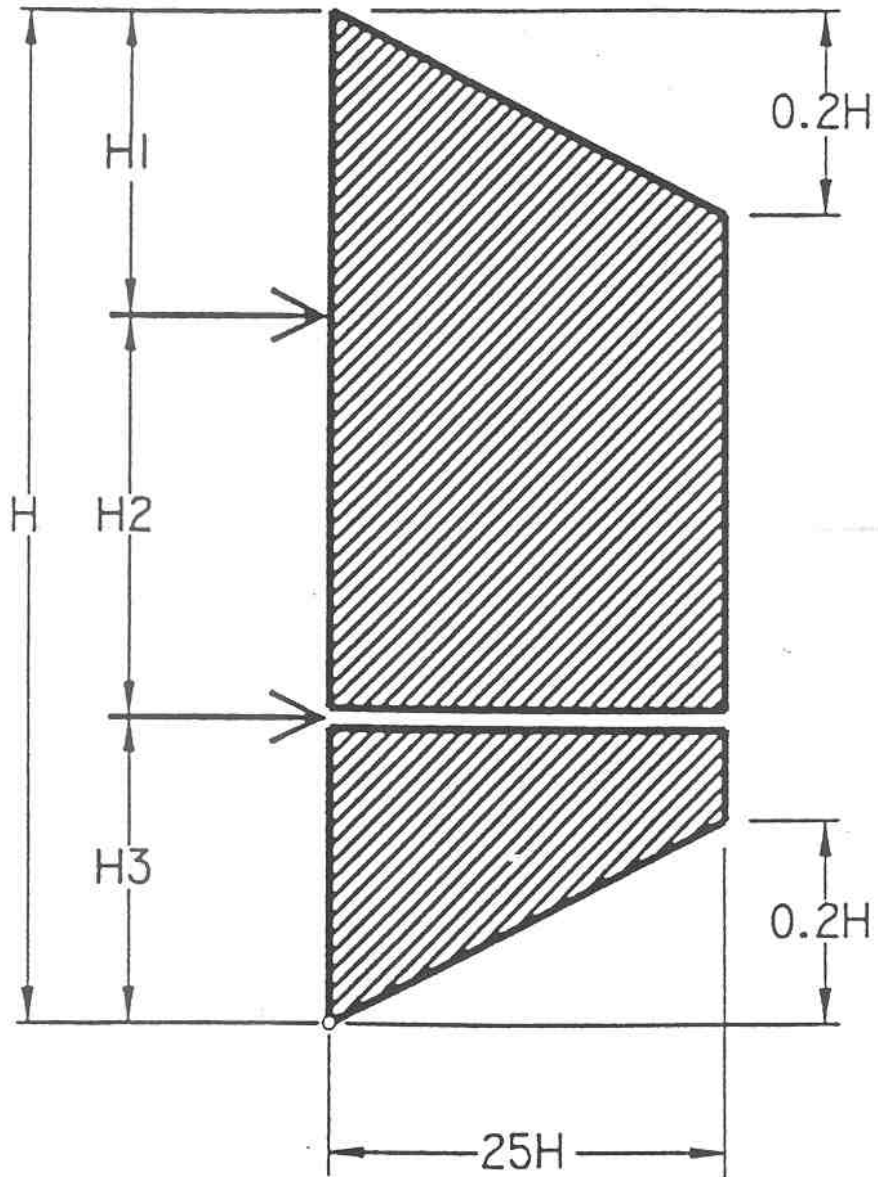


Figure 6. Schnabel's apparent earth pressure diagram (form Schnabel Foundation Company 1996)

conditions such as wall geometry, strength properties, and groundwater may be evaluated much more quickly.

2.1.2.1.3 Apparent Earth Pressures

The Rankine method of active earth pressure utilizes a coefficient multiplied by terms for vertical pressure to estimate the lateral pressure. Differing soils have characteristic equations for this coefficient.

The equations for the AEP coefficient for the three types of soil (sand, soft to medium clay, and stiff clay) in Figure 4 will be introduced here and expanded in the following sections.

2.1.2.1.3.1 Sand

Sand, a cohesionless material, has the following equation for the Rankine coefficient of active earth pressure (Equation 1) for level backfill and a failure surface through the bottom of the cut

$$K_{AR} = \frac{1 - \sin \phi}{1 + \sin \phi} = \tan^2(45 - \phi / 2) \quad [1]$$

2.1.2.1.3.2 Soft to Medium Clay

Soft to medium clays are soils which have a ratio of $\gamma H/s_u$ greater than about six, where γ = unit weight of the soil, H = height of the wall, and s_u = the undrained shear strength of the clay. The corresponding equation for the Rankine active earth pressure coefficient if the failure is through the bottom of the cut is given as Equation 2.

$$K_{AR} = 1 - \frac{4s_u}{\gamma H} \quad [2]$$

If the failure plane passes below the bottom of the cut as shown in Figure 7; Henkel's (1971) method should be used:

$$K_A = 1 - \frac{4s_u}{\gamma H} + 2\sqrt{2} \frac{d}{H} \left(1 - (2 + \pi) \frac{s_{ub}}{\gamma H} \right) \quad [3]$$

It should be noted that if the soil at the base is stiff enough to force a failure plane to pass through the bottom of the cut, the larger of the values produced by Equation 2 and Equation 3 should be used.

2.1.2.1.3.3 Stiff Clay

Stiff clay is a soil which has a $\gamma H/s_u$ ratio less than four. Results of Terzaghi (1996) report that the apparent earth pressure distribution is a total force proportional to $0.75f\gamma H^2$, where f is between 0.2 and 0.4 (see figure 4).

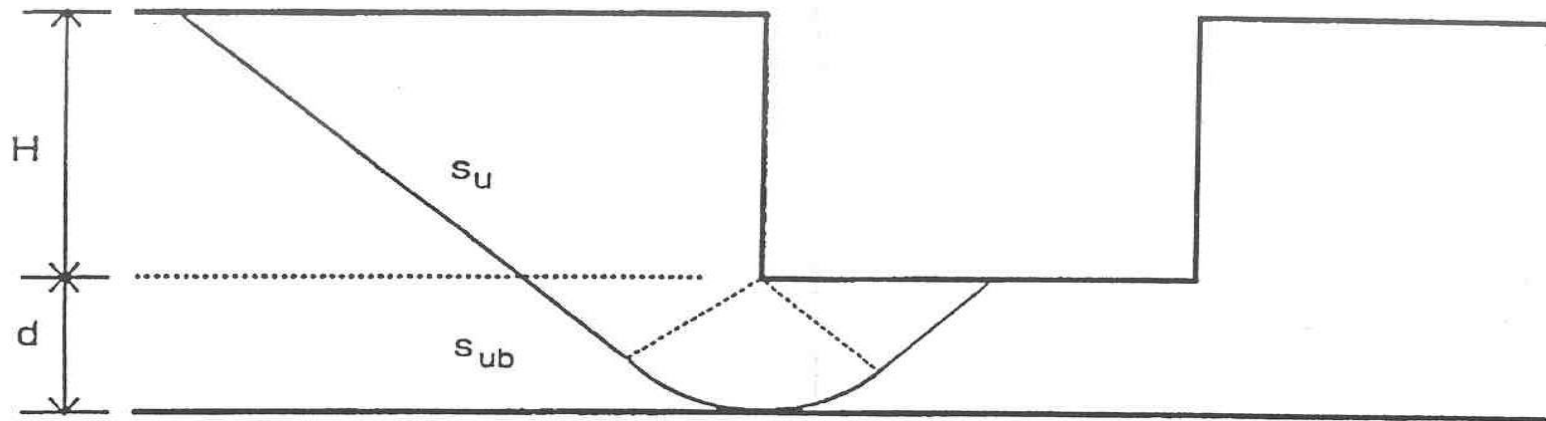


Figure 7. Failure pattern assumed for Henkel's method (from Schnabel Foundation Company 1996)

2.1.2.2 Factors of Safety

There are two basic types of factors of safety (FS) used in these analyses, either based upon strength or based upon load. These factors of safety must occasionally be backcalculated. Each of these cases is defined and explained below. Typical FS values commonly used to design anchors are provided.

In the following discussion of factors of safety, the forces predicted by the Rankine method are assumed to be the actual earth forces which are acting upon the wall. The apparent earth pressures (from the AEP diagrams) are used in the design of the wall. The AEP diagrams estimate larger forces than does the Rankine method; therefore, a factor of safety is established as the ratio of P_{AEP} to P_{AR} .

2.1.2.2.1 Factor of Safety with Respect to Strength

The factor of safety (FS) with respect to strength is defined as the ratio of soil strength available to the soil strength required for stability (*mobilized strength*).

For soils with friction, the basic equation is

$$FS_{strength} = \frac{\tan \phi_{avail}}{\tan \phi_{mob}} \quad [4]$$

For soils with cohesion, the corresponding equation is

$$FS_{strength} = \frac{c_{avail}}{c_{mob}} \quad [5]$$

These equations are applied when the failure surface passes below the structural wall components and behind the ground anchors or when the failure surfaces intersect the anchors themselves or other structural components Figure 8. Common values for this type of FS range from 1.1 to 1.5. Selection of a FS for use in the design depends on a number of considerations, including the importance of the wall, consequences of failure, and economics.

2.1.2.2.2 Factor of Safety with Respect to Load

The basic definition of this FS is the ratio of the load applied to the soil by the anchors to that load required by the soil for stability (Equation 6)

$$FS_{load} = \frac{load_{applied}}{load_{reqd}} \quad [6]$$

This FS is applied when the failure surface passes in front of the anchor as illustrated in Figure 8. In this case, the anchor load affects the stability of the soil since its force is acting external to the failure wedge. Typical values range from 1.2 to 2.0.

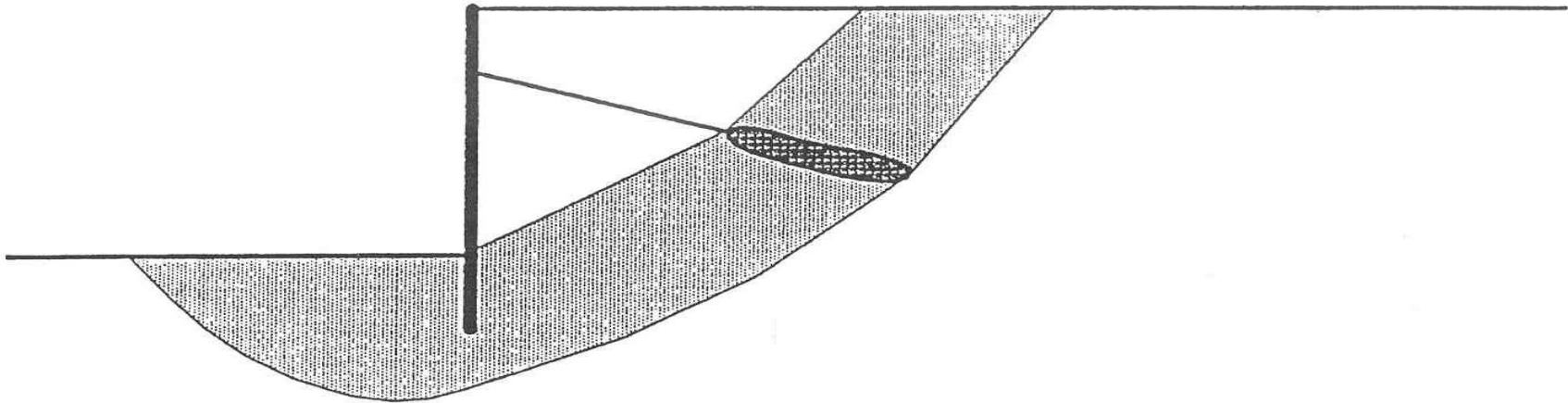


Figure 8. Failure surface used in limit equilibrium analyses of anchored walls (from Schnabel Foundation Company 1996)

2.1.2.2.3 Backcalculated Factors of Safety

Factors of safety with respect to load (FS_{load}) may be backcalculated by comparing the ratio of forces predicted by the apparent earth diagrams to those predicted by the Rankine method of active earth pressures and assuming the Rankine method produces a $FS=1$.

To calculate FS with respect to strength, a value for the mobilized angle of soil friction, ϕ_{mob} , must be calculated. This ϕ_{mob} represents the amount of friction which the soil has developed. It may be calculated by determining the ϕ of the soil required for stability to resist the forces predicted by the apparent earth pressure diagrams. After ϕ_{mob} has been calculated, Equation 4 is used to calculate $FS_{strength}$.

Equations for ϕ_{mob} for the three soil types discussed previously are provided in the following section.

2.1.2.2.3.1 Sand

The FS_{load} for sand is a constant value of 1.3 calculated from the ratio of apparent earth pressure diagram force to Rankine active earth pressures force. This is $FS_{Load} = P_{AEP} / P_{AR} = (0.65K_{AR}\gamma H^2) / (0.5K_{AR}\gamma H^2)$. This value is not influenced by soil characteristics or height of the wall.

For $FS_{strength}$, Equation 7 is used.

$$\phi_{mob} = 2 \left[45^\circ - \text{atan} \left[\sqrt{1.3} \cdot \tan \left(45^\circ - \frac{\phi_{avail}}{2} \right) \right] \right] \quad [7]$$

This equation is derived from the ratios of the two lateral earth pressure coefficients and FS_{load} , thus $FS_{load} = \tan^2(45 - \phi_{mob}/2) / \tan^2(45 - \phi_{avail}/2) = 1.3$. The equation is solved for ϕ_{mob} to yield Equation 7.

For at-rest pressures, Equation 8 provides ϕ_{mob} , while Equation 9 results in FS_{load} .

$$\phi_{mob} = 2 \left[45^\circ - \text{atan} \sqrt{0.95(1 - \sin \phi_{avail})} \right] \quad [8]$$

$$FS_{load} = 0.95 [1 + \sin(\phi_{avail})] \quad [9]$$

Equation 9 is derived using $K_o = 1 - \sin \phi_{avail} = 0.95$, (where 0.95 is a typical value of K_o for sands) and setting $0.95 = K_A/K_o = \tan^2(45 - \phi_{mob}/2) / (1 - \sin \phi_{avail})$. Solving for ϕ_{mob} results in Equation 8.

Anchors should be designed so that the forces exerted by them result in an $FS_{strength}$ of 1.2 to 1.5 to match current design procedures. A FS of around 1.3 will result in design loads similar to walls designed to support AEP. Walls with a FS of 1.0 to 1.2 may be mechanically stable but may also exhibit unacceptable displacements.

2.1.2.2.3.2 Soft to Medium Clay

FS_{load} is a constant value of 1.75 regardless of soil strength or height of the wall. This value results from a ratio of the apparent earth pressure force to the active Rankine earth pressure force.

Determination of $FS_{strength}$ requires that mobilized undrained shear strength ($s_{u\ available}$) be back-calculated first, using $0.5\gamma H^2 (1-4s_{u\ available}/\gamma H)$ and applying the apparent earth pressure to the face of the cut. Then, Equation 5 may be used with this result to yield the $FS_{strength}$. $FS_{strength}$ usually varies from 1.25 and 1.5, but should be greater than 1.5 for a soft clay.

2.1.2.2.3.3 Stiff Clay

FS_{load} cannot be defined for a stiff clay (one where $\gamma H/s_u < 4$) since the strength is theoretically high enough that no support is necessary.

$FS_{strength}$ is determined by comparing the available strength of the clay to the minimum strength of the clay required for support. The following equation is used (Equation 10).

$$FS_{strength} = \frac{4}{\frac{\gamma H}{s_{u\ available}} (1 - 1.5f)} \quad [10]$$

In Equation 10, f is a constant with a value from 0.2 to 0.4. Since $FS_{strength}$ becomes very large for small values of $\gamma H/s_u$, undrained strength stability analyses for stiff clays are unreliable for design.

Alternatively, a stiff clay may also be modeled as an equivalent soil which possesses friction. An equation for ϕ_{mob} which results from a back-calculation using AEP and active earth pressure (Equation 11) is

$$\phi_{mob} = 2(45^\circ - \text{atan}\sqrt{1.5f}) \quad [11]$$

The friction angle may be assigned using results of strength tests, classification tests, or geologic origin. This method likely overpredicts the pressures needed to support the soil, since it ignores soil cohesion. Cohesion may need to be included to make the required force more realistic.

The active earth pressure should not be used for anchored walls in stiff clay. Instead, apparent earth pressures should be used. The anchors should be designed to support the largest anchor load determined by the AEP method.

2.1.2.3 Limit Equilibrium Anchor Force Design Procedure

A design procedure to evaluate forces exerted on walls and, consequently, the forces required to be resisted by anchors, is now presented for three different soil types. It is based on limit equilibrium and Rankine methods.

2.1.2.3.1 Introduction

The principle behind the use of a limit equilibrium design is that the amount of force required to support soil is equal to that which is exerted on the wall by the portion of the slope that will fail. This portion is known as the active wedge. The force needed to support the active wedge, calculated by summing the forces in the vertical and horizontal directions, may be used to determine the force that the wall, and therefore the anchors, must exert. If the failure surfaces are drawn at any point between the end of the anchor and the active wedge, this design approach may

be used to determine desired design criteria of total anchor force and overall stability of the soil/anchor system acting as a mass.

Figure 9 is the basic diagram for the limit approach design. Variables in the diagram are defined as follows:

- P_{AR} = active soil pressure
- W = soil weight
- R = soil resistance along bottom surface
- SP_H, SP_V = horizontal and vertical forces supplied by anchors extending outside of the active wedge
- T = resistance provided by anchor

The value of T varies according to the position of the grouted portion of the tendon. If the active failure plane is in front of bonded length, the anchor force developed by the entire grouted portion of the tendon may be used. For cases where the plane is behind the bonded length, no anchor force may be used. Finally, if the plane passes through the bonded length, only the force which may be developed by the portion of the anchor behind the failure plane may be used.

This diagram (Figure 9) and the sum of horizontal and vertical forces is used as a basis for analysis.

2.1.2.3.2 Failure Plane Location

Since the location of the failure plane is important in defining the modes of failure which may occur in anchors, it will be discussed here. The anchor should always be placed well behind any potential failure planes so that the full length of the grouted portion of the anchor may be used to develop resistance.

There are three methods of determining the beginning of the anchor zone as depicted in Figure 10. The first method is based on Rankine analysis and assumes that the failure plane passes through the bottom of the wall and is angled at $\alpha = 45 + \phi/2$ with respect to horizontal. Therefore, the anchor must be placed behind this plane.

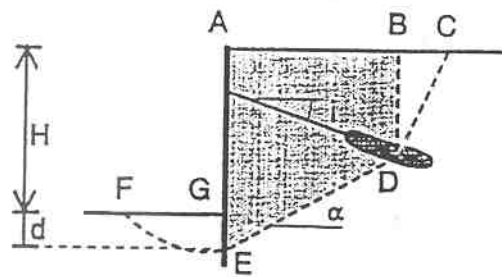
Peck, et. al. (1974) proposed a second method by expanding on Rankine's idea. The failure plane location is calculated as in Rankine's method. The anchored zone then begins a distance of $1/5$ the height of the wall behind the failure plane.

A third method is to base the location of the failure plane on the results from the force equilibrium method. The location of the failure plane is determined from the combination of angle and depth which produced the maximum P_{reqd} .

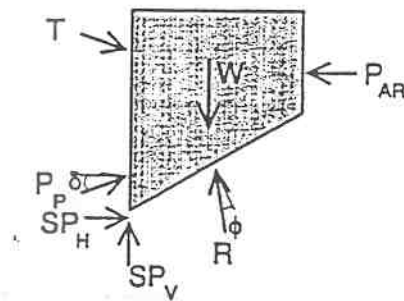
A comparison of the three schemes is shown in Figure 10 for level backfill and in Figure 11 for sloping backfill. Factors which affect the location of the plane include nonhomogeneity, surcharges behind wall, groundwater, and seepage. Schnabel (1996) suggests that, in general, the force equilibrium method gives the best results.

2.1.2.3.3 Simple Failure Surface Analysis

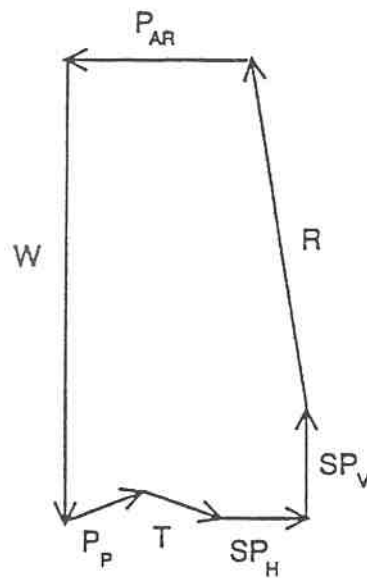
As an introduction to the development of the design procedure, a fairly simple case is presented consisting of vertical wall supporting a level backfill of sand only. Figure 12 shows an anchored wall system in sand. In this diagram, the sand has an angle of internal friction ϕ , unit weight γ , and height H . The unbonded length of the anchor is far behind the critical failure plane so that the full anchor resistance may be used. The failure plane passes through the toe at d and



a) example tieback wall system



b) free body diagram



c) force vectors acting on area ABDEG

Figure 9. Force equilibrium consideration for an anchored wall system (from Schnabel Foundation Company 1996)

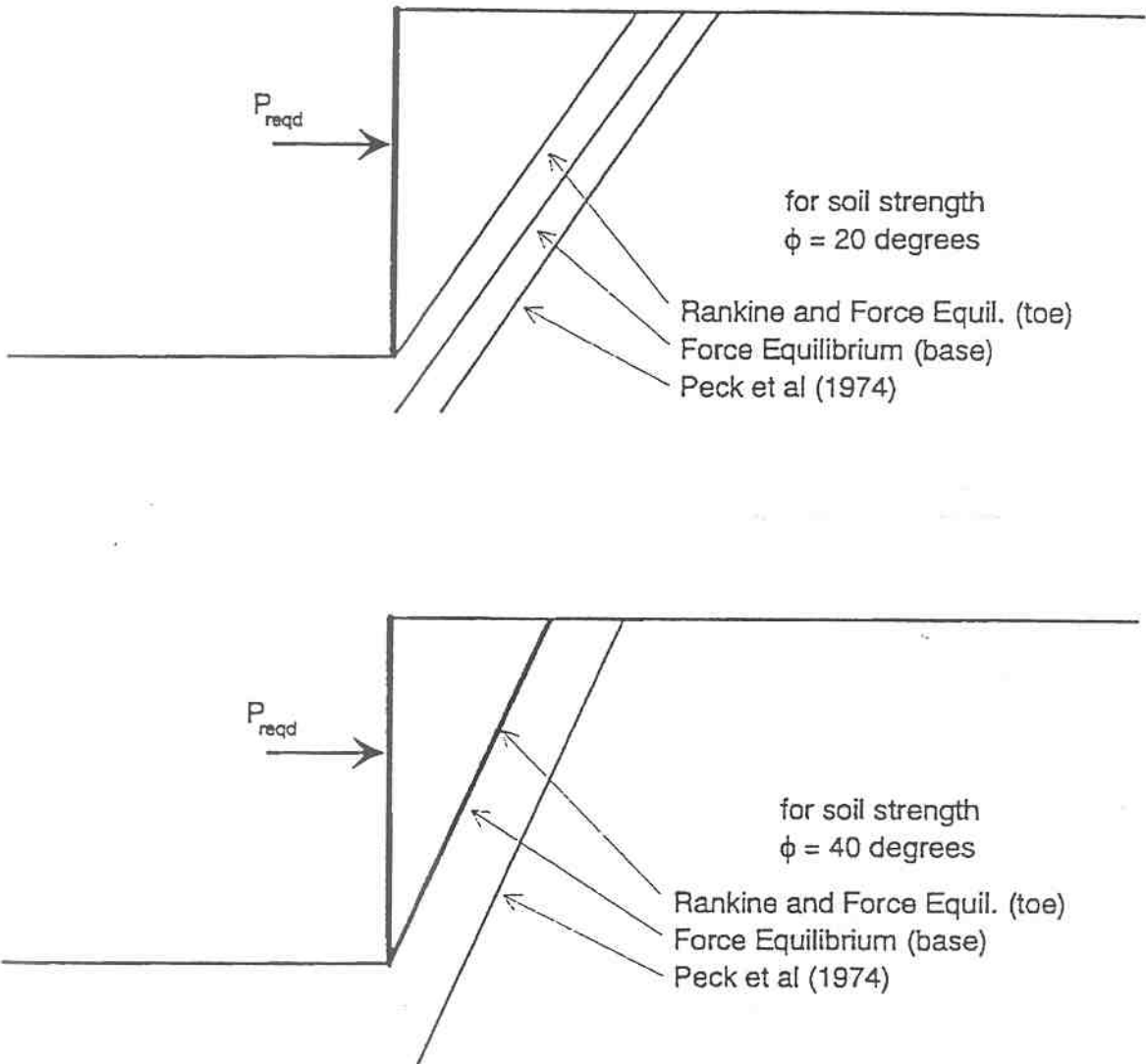


Figure 10. Comparison of method for determining minimum unbonded length, horizontal backfill (from Schnabel Foundation Company 1996)

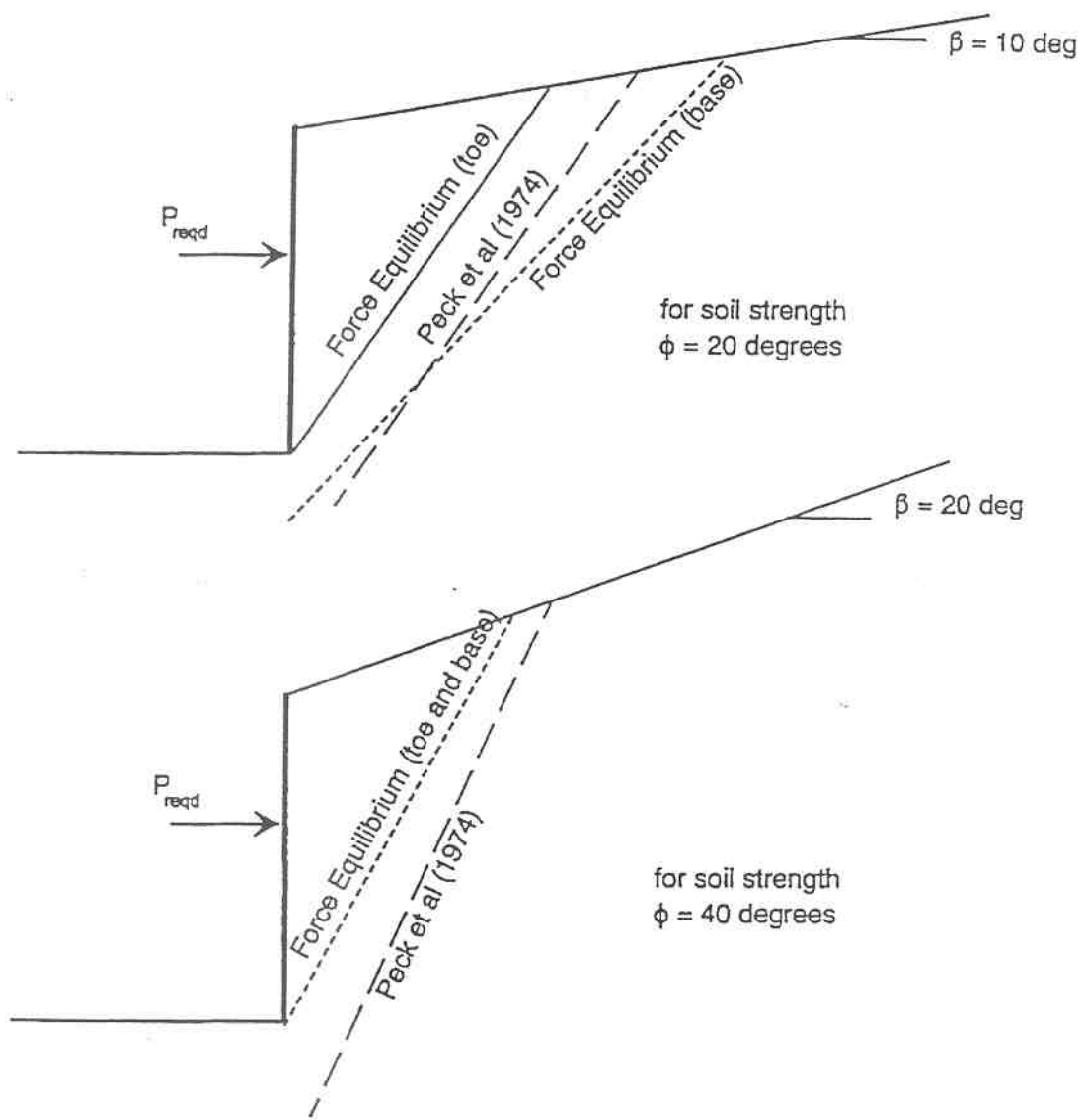
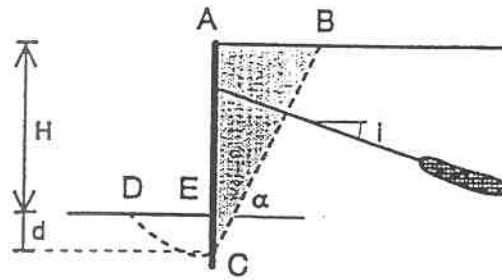
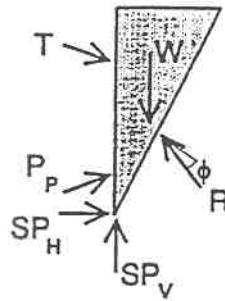


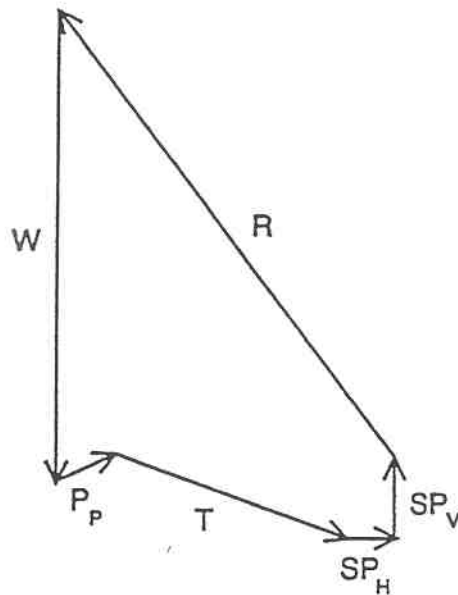
Figure 11. Comparison of method for determining minimum unbonded length, sloping backfill (from Schnabel Foundation Company 1996)



a) example tieback wall system



b) free body diagram



c) force vectors acting on area ABCE

Figure 12. Forced equilibrium considerations for anchored wall systems, failure surface in front of bonded length (from Schnabel Foundation Company 1996)

mobilizes passive resistance from the soil, P_p . This passive resistance has a value equal to $P_p=1/2\gamma d^2 K_p$. K_p may be determined from a diagram such as Figure 13.

The horizontal and vertical resistances from the soldier pile are represented by SP_H and SP_V , respectively. The assumption is made that the vertical component of the anchor resistance T is fully supported by the soldier pile; therefore, SP_V is equal and opposite to it. Consequently, the horizontal force of the soldier pile, SP_H , is equivalent to the horizontal force which must be exerted by the anchor, P_{reqd} (equal to $T \cdot \sin(i)$).

A solution for P_{reqd} may be found by adding and combining the equations for horizontal and vertical forces. The result is given by Equation 12 and is based upon the configuration shown in Figure 12.

$$P_{reqd} = \frac{1}{2} \gamma H^2 \left[\frac{(1 + \xi)^2}{\tan(\alpha)} - K_p \xi^2 \left(\sin(\delta) + \frac{\cos(\delta)}{\tan(\alpha - \phi)} \right) \right] \tan(\alpha - \phi) \quad [12]$$

A solution is found by varying ξ (which is defined as d/H) and α until a maximum for P_{reqd} is achieved, a process which may be facilitated by use of a computer spreadsheet. This method compares well with more in-depth analyses such as force and moment equilibrium or assuming a non-linear failure plane. (Schnabel 1996 p. 8-29)

2.1.2.3.4 Using Limit Equilibrium for Design

A design approach for a more general case is now presented which includes sloping backfill and various soil types for each of the three basic stability modes as defined by the location of the failure plane.

Internal stability is when the failure plane is completely within the unbonded portion of the anchor. Failure planes completely behind the anchor are analyzed as *global* (also called *external*) stability, while a failure plane which falls within the anchor zone is referred to as *intermediate stability*.

2.1.2.3.4.1 Internal Stability

The internal stability case is illustrated by Figure 12. The relevant equation for P_{reqd} is Equation 13

$$P_{reqd} = \frac{1}{2} \gamma H^2 \left[\frac{(1 + \xi)^2}{\tan(\alpha) - \tan(\beta)} - K_p \xi^2 \left(\sin(\delta) + \frac{\cos(\delta)}{\tan(\alpha - \phi)} \right) \right] \tan(\alpha - \phi) \quad [13]$$

Equation 13 is solved by varying ξ and α until a maximum P_{reqd} is found.

The combination of angle and depth identifies potential failure surfaces by describing its geometry.

2.1.2.3.4.2 Global Stability

Global stability is illustrated in Figure 14. Since the anchors are spaced at a distance of s , the failure plane may have a 3-dimensional shape between the anchors. In effect, the failure plane may form a "zigzag" pattern in plan, with the plane passing behind each anchor but in front of

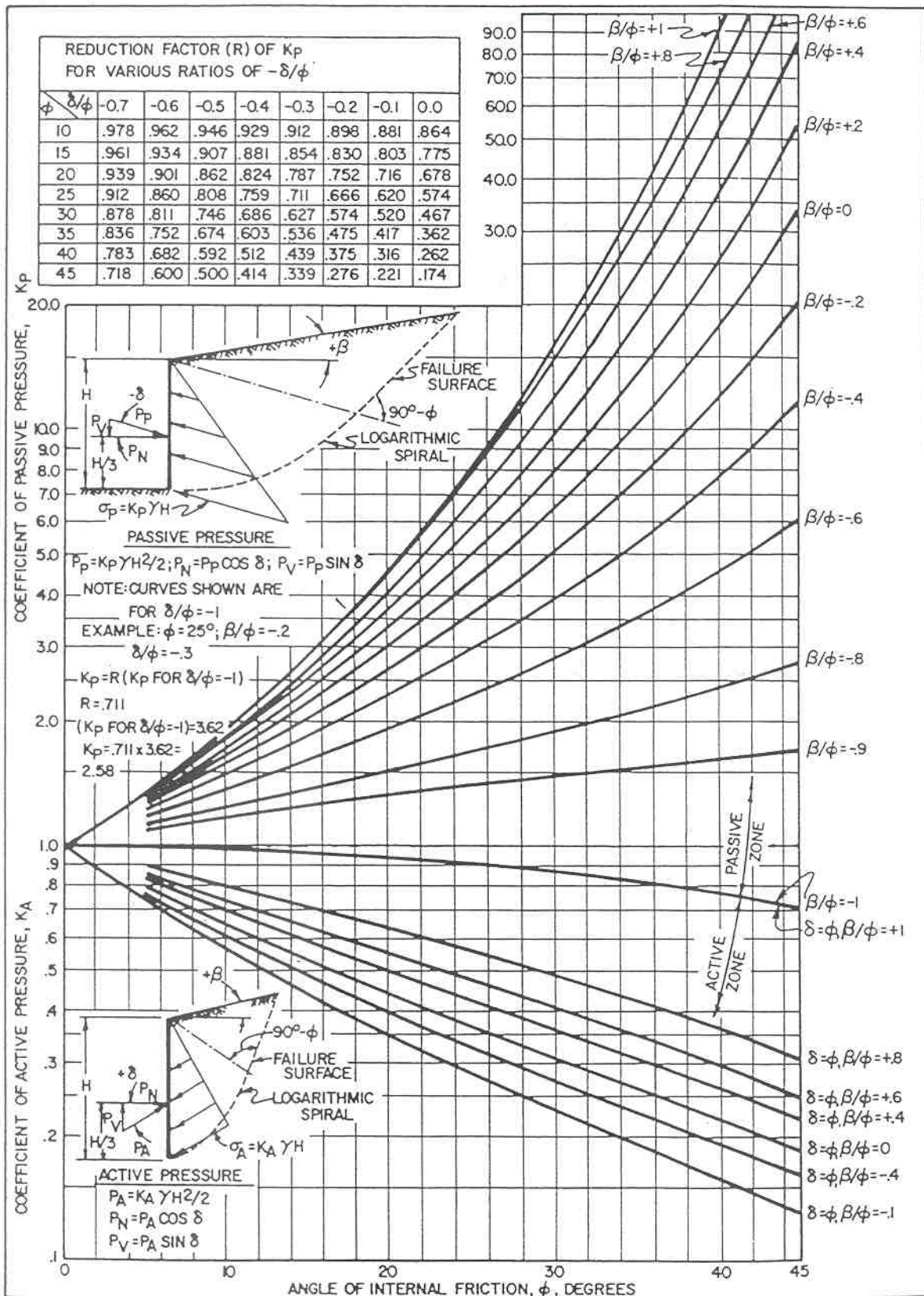
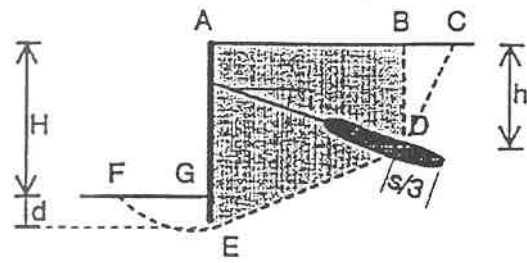
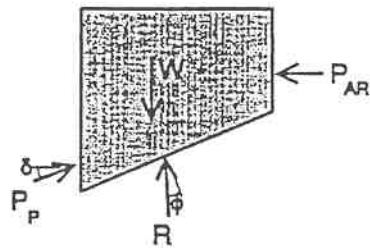


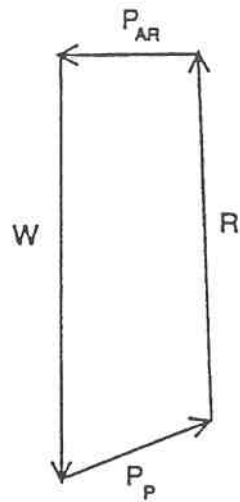
Figure 13. Active and passive earth pressure coefficients (from Navy 1982)



a) example tieback wall system



b) free body diagram



c) force vectors acting on area ABDEG

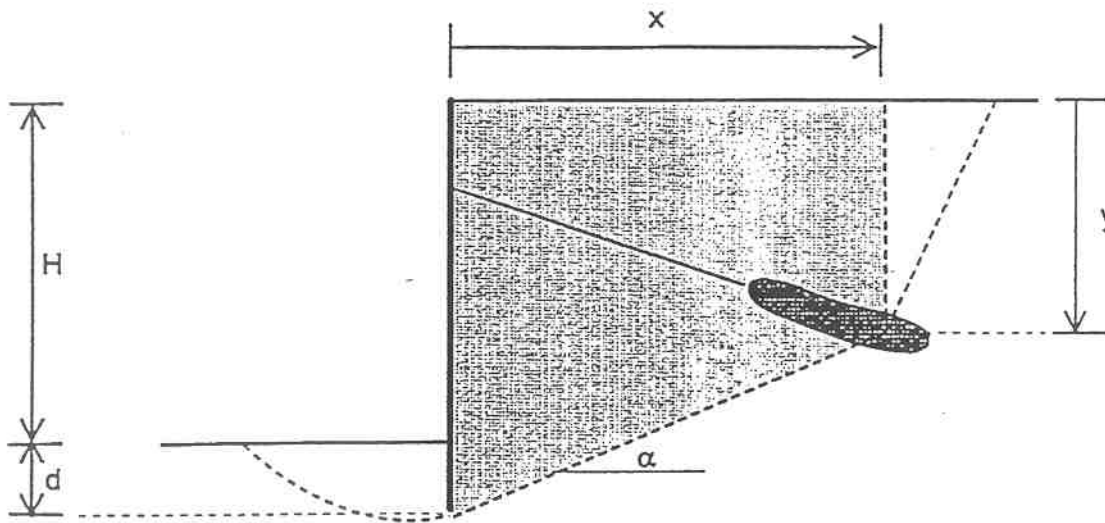
Figure 14. Force equilibrium considerations for anchored wall systems, failure surface behind the anchor (from Schnabel Foundation Company 1996)

the anchor in the portion between anchors. For a 2-D analysis, the assumption is made that the failure plane intersects the anchor at $s/3$ measured from the back of the anchor.

Forces acting on each face of the soil wedge are defined in Figure 14. On the left face, passive soil resistance (P_P) acts at angle δ . This passive resistance may be determined from $P_P = 1/2\gamma d^2 K_P$, with $\delta = \phi$. On the right side, the AEP calculated assuming Rankine active conditions is $P_{AR} = 1/2\gamma h^2 K_{AR}$, where $h =$ length of BD and $K_{AR} =$ the Rankine active earth pressure as defined by Equation 1. These forces, along with the soil frictional resistance (R), may be broken into horizontal and vertical components and summed to yield the following equation for force required to assure global stability (Equation 14).

$$(1 + \xi + \lambda)\chi - K_p \xi^2 \sin \delta + \frac{K_p \xi^2 \cos \delta - K_A \lambda^2}{\tan(\phi - \alpha)} = 0 \quad [14]$$

In Equation 14, χ , λ , and ξ are as defined in Figure 15. The solution method is to specify the position of the back of the anchor, vary the depth (ξ), and then solve for the maximum soil strength (ϕ) required to satisfy Equation 13.



$$\chi = x/H$$

$$\lambda = y/H$$

$$\xi = d/H$$

Figure 15. Definition of non-dimensional parameters χ , λ and ξ (from Schnabel Foundation Company 1996)

As soil strength is reduced, the failure plane moves lower and lower. If soil strength continues to be reduced, the failure plane may pass below the bottom of the cut. A situation may be reached in very poor ground where the failure plane may extend deeper than the toes commonly used for anchored walls. If this is the case but the wall is excavated to an underlying layer of rock or firm soil, base failure cannot occur. In this case, the stability is evaluated based upon the failure plane passing through the bottom of cut, and Equation 15 is used.

$$\chi(1 + \lambda) - \frac{K_A \lambda^2}{\tan(\phi - \alpha)} = 0 \quad [15]$$

In Equation 15, $\alpha = \text{atan}((1-\lambda)/\chi)$.

2.1.2.3.4.3 Intermediate Stability

The last stability case, intermediate stability, occurs when the failure plane occurs through the anchor. The analysis for this case is similar to that shown in Figure 9. Such a failure has never been reported. However, since the FS may be less than for a plane in front of or behind the anchor, this case must be investigated. The fact that the failure plane passes in front of the bonded zone means that the amount of anchor resistance that may be applied is reduced (Equation 16).

$$\frac{P_{TP}}{\frac{1}{2} \gamma H^2} - K_A \lambda^2 + K_P \xi^2 \cos \delta - (K_P \xi^2 \sin \delta - (1 + \xi + \lambda) \chi) \tan(\phi - \alpha) = 0 \quad [16]$$

Figure 16 depicts a graphical solution of Equation 15 for a soil with $f = 33^\circ$ and an anchor force P . The lines represent the back of the failure surface. The solution was calculated by choosing a vertical elevation for the back of the failure surface (l), evaluating various horizontal distances (c) for the largest value which will still satisfy Equation 16 and also varying x until Equation 16 was solved.

2.1.3 Anchor Characteristics

2.1.3.1 Types of Anchors

The tendons used to anchor tieback walls must be anchored to the surrounding soil and/or rock. The engineer must decide which basic type of anchor system to use. Hanna (1982) suggests the following three types of anchors, which are illustrated in Figure 17.

1. Simple cylinder. A hole is drilled in the soil or rock and filled with grout. This type is typically used for anchors embedded in rock.
2. Cylinder enlarged by grout pressure. In this case, a hole is drilled as with the simple cylinder. However, the grout is forced into the hole under pressure. If the soil is permeable, a larger bell-shaped area is formed as the grout pushes the soil aside and permeates some of the pores. A low grout pressure causes the grout to flow into the pores, while a high pressure results in the formation of "bulbs" which expand beyond the diameter of the borehole.

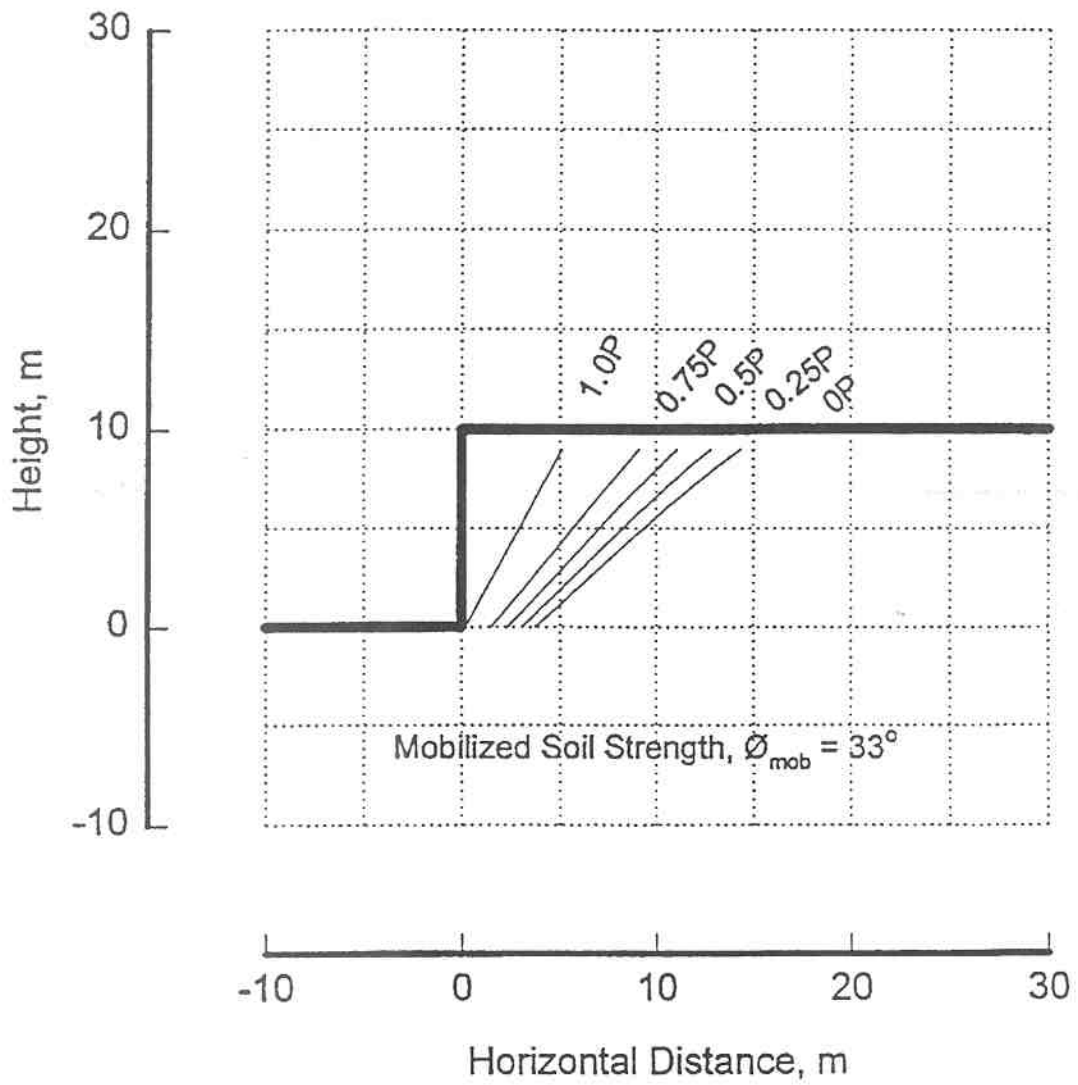
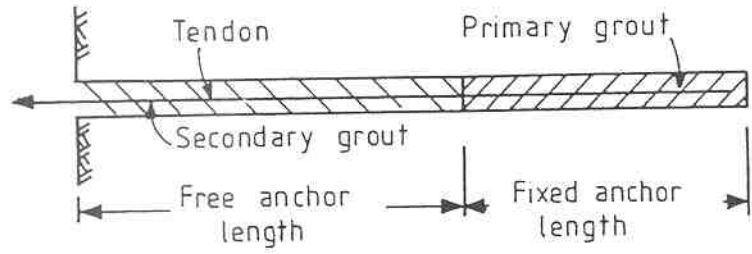
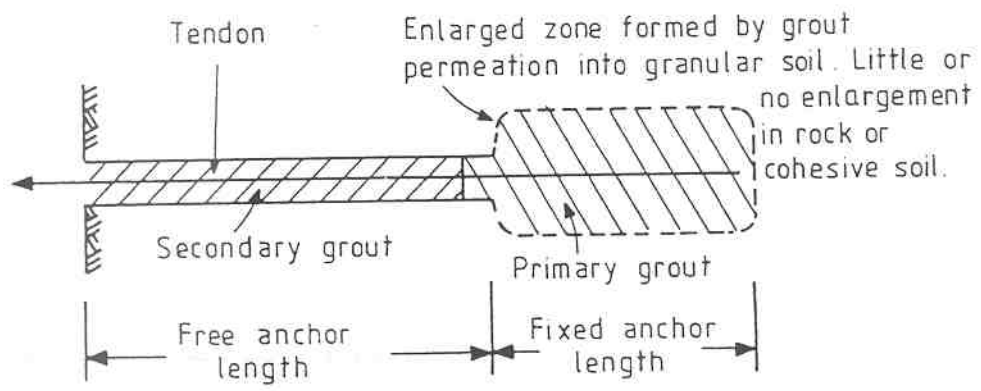


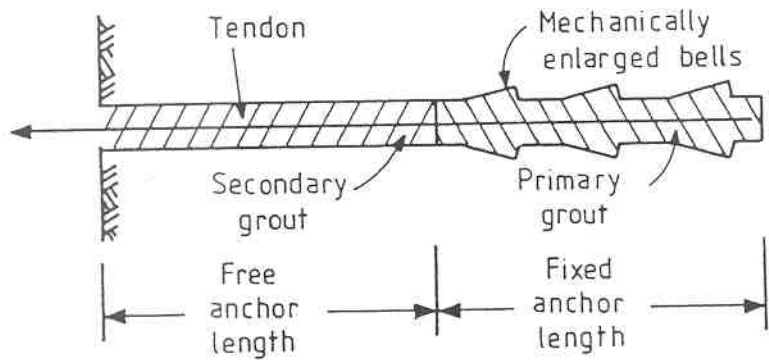
Figure 16. Requirements for anchor load along the anchor length (base failure) (from Schnabel Foundation Company 1996)



TYPE 1 ANCHOR CYLINDER FILLED WITH GROUT



TYPE 2 ANCHOR CYLINDER ENLARGED BY GROUT INJECTED UNDER HIGH BUT CONTROLLED PRESSURE



TYPE 3 ANCHOR A CYLINDER MECHANICALLY ENLARGED AT ONE OR MORE POSITIONS ALONG ITS LENGTH.

Figure 17. Types of ground anchors (from Hanna 1982)

3. Cylinder enlarged by mechanical means. A hole is drilled in soil with a special device which causes "underreaming." This underreaming creates bell-shaped enlargements at intervals throughout the grout area. Note that in this case, only portions of the grout cylinder are enlargements, unlike the previous type in which the entire cylinder is enlarged.

All of these methods are suitable for a soil in which a hole may be drilled without collapsing. However, the second type is usually used when the drilled hole will not stay open, but may be used in either case.

This is only one of several methods for classifying anchors. Schnabel (1982) lists four types of anchors which consist of all combinations of two anchor shapes (cylindrical and enlarged) and two grout application techniques (low or high pressure).

Since design of anchors is closely related to the type of grout used, this topic will be discussed in the Grout Design section (Section 2.1.3.3).

2.1.3.2 Tendons

2.1.3.2.1 Types

Plain and threaded steel bars, pipes, rods, and wire or cables may be used for the tendon portion of the anchor. This report will be limited to wire tendons since they are the most common type. Wire has several advantages over bars and rods, including higher flexibility, higher elasticity and higher tensile strength (Xanthakos 1991). Also, strands provide redundancy by utilizing multiple wires.

Anchors may be constructed of an individual wire. However, stranded anchors are often used in which multiple wires are wound around a central core. Hanna (1982) and Hobst (1983) provide details regarding the various wire arrangements and number of wires that form the common strands. Typically, seven, twelve, or nineteen steel wires of diameters ranging from 4.0 mm to 7.0 mm (0.16 to 0.28 in) and minimum tensile strength of 1,600 to 1,700 MPa (16,700 tsf to 17,800 tsf) are used in anchor cables. Often, the same wire and cable which are used for prestressing concrete are utilized for ground anchors.

2.1.3.2.2 Design

2.1.3.2.2.1 Design Criteria

Mechanical strength, elastic properties, creep response, and relaxation behavior are important parameters for tendon design. Some discussion of common terms is necessary.

Characteristic strength (f_{pu}) is the strength below which no more than 5 percent of samples will fail and is also called the guaranteed limit, ultimate tensile strength, and guaranteed minimum ultimate tensile strength. *Proof stress* (T_G) is the stress at which a certain percentage elongation occurs. For example, a common value of "0.1 proof stress" is the stress at which 0.1% elongation occurs. *Creep* is the tendency of a tendon to deform under constant tension even at levels below the elastic limit. Creep of a tendon under constant stress is an exponential function of time; however, creep behavior of a tendon which is experiencing repeated loading is not well understood. *Relaxation* occurs when a tendon experiences constant strain over a period of time. Elastic strain is replaced by plastic strain, and a reduction of elastic stresses occurs. Xanthakos (1991) suggests a typical relaxation as 5-10%, the vast majority of which occurs in the first hour. Hence, the tendon may be initially overloaded to allow for the occurrence of relaxation.

Specifications for stress-relieved wires are found in ASTM A421-91 and for stranded wires in ASTM A416-74.

2.1.3.2.2.2 Design for Stress

Tendons must be designed against failure from overstressing. The characteristic strength (f_{pu}) and proof stress (T_G) of the tendon along with a factor of safety are used in design. Other factors such as allowances for creep and conditions of the head, end block, and connections of the tendons may reduce the allowable stress to a level below the tendon's capacity. The tendons and wall must resist earth pressure, water pressure, and wall surcharges.

Common **factors of safety** are 1.6 for temporary anchors and 2.0 for permanent installations. Therefore, the tendon capacity would be selected by multiplying the maximum expected working load by the appropriate factor of safety. Design aids provided by manufacturers may then be used to select the appropriate tendon material which must then be tested to provide quality assurance.

2.1.3.2.3 Corrosion Resistance of Unbonded Tendons

Corrosion protection of the anchor tendon will be discussed in this section. Corrosion protection of the anchor head is discussed in the "Anchor Head Design" section, while corrosion of the tendon in the bonded length (where the tendon is in contact with grout) is discussed in the "Grout Design" section 2.1.3.3.

2.1.3.2.3.1 Introduction

An important aspect of tendon design is protection against corrosion. Since the wires comprising the tendons are composed of steel, they are subject to corrosion and as a result may be weakened, perhaps to the point of failure.

In general, corrosion results when metals return to a more stable state. Since the metals used in steel are processed away from their natural state, the tendency is for the metal to return to the more chemically stable, but less structurally sound, state. This corrosion results when a galvanic cell is formed. In a galvanic cell, an electric current is developed and causes metals at the anode to corrode at a rate which is directly proportional to the current flow and time. Galvanic cells may be formed when two metals are "connected" by an ionic solution, when two different metals are in contact (which can include imperfections on the same substance), or when a metal experiences two different zones of ionic strength, such as differing oxygen concentration or pH.

These galvanic cells may attack metal in different ways. In a generalized attack, there are no localized anodes or cathodes. Instead, there are equal areas of anode and cathode whose corrosion products may stop corrosion. In contrast, a localized attack occurs when there is a difference in potentials on the surface, perhaps due to imperfections. Pits and cracks may form which can result in minimal total metal loss but severe corrosion as the pits and cracks penetrate deeply into the metal surface and perhaps corrode completely through the tendon.

Sulfate-reducing bacteria may produce bacterial attack and in some cases, the byproducts may produce sulfuric acid which further accelerates the corrosion. Stress cracking results when a small crack allows large stresses to concentrate, which in turn produces more fresh metal surfaces for corrosion to attack. This may also occur if hydrogen works its way into the crystal structure of the metal. The increased pressure allows cracks to develop, thus exposing uncorroded metal surface.

Tendons are in contact with the ground. Therefore, the potential of surrounding soil to cause corrosion is a major factor in determining proper protection of tendons. Properties of the soil such as ion content (chloride and sulfate, for example), water content, permeability, and redox potential must be known to characterize the aggressivity of the soil. Based on the relative corrosivity of the soil, appropriate measures may be taken to protect the tendons.

Methods to quantify corrosion are imprecise; in fact, Hanna (1982) states that orders of magnitude only may be assigned to corrosion. Hanna also lists seven soil characteristics that play a role in aggressivity. Soil resistivity is the electrical resistance of the soil; lower resistivity results in higher potential for corrosion. Redox potential gauges the corrosion potential from microbes. Heavy clay soils are most prone to this type of attack, and high moisture content, a low redox potential, and a sulfate, organic and soluble ion content further exacerbate the problem. In addition, an anchor which passes through a zone of low redox potential and then through a high redox potential soil may establish a galvanic cell. Moisture content of soil plays an important but ill-defined role in corrosion. In general, low moisture content favors pitting while high moisture content favors general and bacterial corrosion.

Salts in general increase the likelihood of corrosion by decreasing soil resistivity. However, carbonates reduce the corrosion potential. pH affects the type of corrosion more likely to occur. In soils of low pH (< 4), pitting is more likely, while a slightly alkali soil favors corrosion by sulfate-reducing organisms. Organic content of soils indicates the likelihood that organic acids will cause pitting. Finally, oxygen transfer rates provide information regarding corrosion potential since high oxygen rates result in high corrosion.

Since many of these factors are variable throughout the year, care must be taken to consider how a soil's corrosivity may change with time. Generally, propensity toward corrosion decreases with increasing time. Cohesive soils are generally more corrosive since they have a high resistivity, low sulfate and organic content and an alkaline pH. Hanna (1982) provides the following as a general guide to soil corrosivity, given in order of decreasing corrosivity: made ground, organic soils, clays, silts, sands, gravels.

Littlejohn (1986) lists several cases where consideration of corrosion protection should be made: anchors exposed to high levels of corrosive ions such as sea water, salt lake beds, and proximity to chemical plants; those in saturated clay soils with low oxygen and high sulfate content or any soils which experience fluctuating ground water levels or partially saturated conditions; anchors which pass through zones of varying conditions with regard to ion concentration or oxygen concentration; and anchors which experience cyclic loading.

2.1.3.2.3.2 Protection Methods

Determining the amount of protection required is difficult. Since rates of corrosion are impossible to predict accurately, some form of protection should be used in all permanent anchors and in most temporary anchors since unprotected tendons may survive only a few weeks in very corrosive conditions.

Littlejohn (1986) regards the following as critical properties of any tendon protection system: a life-span equal to or exceeding that of the tendon; construction so that the tendon may move freely (in case restressing is required) and which will not reduce the tendon capacity; and a durable material which will not need to be replaced, which will survive proof-testing, and which will not be damaged during transportation or construction.

The main method to prevent corrosion is to prevent an atmosphere which is conducive to corrosion from contacting the tendon. One common method is to coat the tendon with a

corrosion resistant material. Various coatings may be used, but all should be applied at the factory to ensure adequate quality. For temporary anchors, bituminous and metallic paints, bonded metallic coatings, or tapes impregnated with polypropylene or grease may be used. Plastic sheaths, which are applied after a tendon has been coated with a substance such as grease, are commonly used. Metal sheaths are suitable only if the metal is thick and compatible with the tendon metal.

Another method is to surround the tendon with a fluid. Cement grout, free from corrosive components such as sulfate, is commonly used for this purpose. Bitumen-based fluids and greases are used. In every case, care must be taken to ensure that the fluid is compatible both with the tendon material and with any sheathing which may be placed over the tendon.

The sacrificial anode is a rarely used method. This process involves passing a current through the ground and providing an anode for the current to corrode. However, this method is not popular for ground anchors for several reasons: high cost from required periodic replacement of anodes, need for protection over the entire length of cable, uncertainties regarding the necessary current flow, and the increased construction complexity resulting from extra cables (Hanna 1982).

2.1.3.3 Grout

Grout, a mixture composed of cement, water, and possibly admixtures, is a very important consideration in the design of anchor systems since it is the grout-soil bond which secures the anchor in the ground. This section discusses the functions of grout, the composition of grout, design methods for determining the capacity of a grout, and corrosion of the grout, and corrosion of the tendon by the grout.

2.1.3.3.1 Functions

Although the primary function of grout is to transfer the load of an anchor to the ground, grout does serve other functions. These include providing protection for the tendon against corrosion (Sections 2.1.3.2.3 and 2.1.3.4.2). Also, grout may enhance the bearing capacity of the soil.

2.1.3.3.2 Composition

Hanna (1982) presents a few key factors which cause variation in the strength and durability of grout. These include variable quality of the materials as well as different types of cement which may be used (the common Portland cement, as well as sulfate resistant or rapid setting).

The basic ingredients of grout are cement, water, and possibly admixtures. Usually local design standards govern the grout mix. The choice of cement depends largely on corrosion considerations. Type I, Portland cement, can be used when the corrosion potential is low. Type II, sulfate-resistant, and Type III, rapid hardening, provide more resistance to corrosion. The water to cement ratio (by weight) is the most critical factor, with a value of 0.40 to 0.45 being typical. The water must be free of organics, sugars, or chlorides which could accelerate corrosion.

Admixtures may include fillers such as sand or chemical agents which serve to accelerate hardening, improve flow, or control shrinkage. However, there are no standards for the use of admixtures, and complete testing of a potential admixture must be made to ensure that it enhances performance and does not increase the risk of corrosion.

2.1.3.3.3 Design

The primary consideration in designing a grout mix is corrosion, both of the grout itself and corrosion of the tendon by the grout. This topic is discussed more completely in the Corrosion considerations section (2.1.3.3.4).

The second most important criteria for grout selection and anchor design is assuring sufficient strength is provided to secure the anchor to the ground. There are two possible failure modes: failure of the bond between the grout and the ground and failure of the grout-tendon bond.

2.1.3.3.3.1 Grout-Ground Bond Design

Since anchors are usually buried fairly deeply, the likelihood that the soil will fail (i.e., that the soil wedge above the anchor will pull out) is small. Therefore, the important design consideration is to ensure that grout-ground bond is sufficiently strong.

Xanthakos (1991) provides the following equation for average bond strength for a straight anchor of uniform size: $P = \pi DL\tau$, where τ = the average bond strength, D = effective grout column diameter, and L = fixed anchor length. τ may be calculated as $\tau = c_a + \sigma_n \tan \delta$, where c_a = adhesion between the grout and soil, σ_n = normal effective stress on the anchor zone, and δ = friction angle between the soil and grout. This approximation is valid if load transfer is uniform throughout the length of the anchor, the borehole and the fixed length have the same diameter, failure occurs by sliding at the grout-ground interface or by failure of a weaker soil surface beyond the interface, debonding does not occur at the tendon-grout interface, and no weak planes are present in the soil. Schnabel (1982) suggests that in general, the bond strength for all soils except softer clays will be about 47,900 Pa (1,000 psf). Xanthakos (1991) gives more detailed suggestions for different soil types on his p166.

Hobst (1983) lists some general criteria that may be used for anchors installed in rock. He suggests that a laboratory test may be used to determine the bonding strength. Also, a general rule is that the bonding strength may be estimated as 1/10 the compressive strength of the rock or the strength of the set grout, whichever is smaller, divided by a high factor of safety (3 to 4). However, the most reliable method is to test anchors which have been installed on-site, then applying a factor of safety of 1.5 to 3.5 as determined by general condition of the rock (weathering, fracturing, etc.). Xanthakos (1991) tabulates values of bond for many rock types on his pages 145 and 151.

Chapter 4 of Hanna (1982) offers a very detailed treatment of the grout-ground bond in both anchor and rock, as does Chapter 13 of Hobst (1983). For the simple case of a cylindrical borehole, the required length of the bond can be calculated from

$$L = \frac{T}{\text{circumference} \times \text{shear strength of grout}}$$

where

L = required bonded length, and

T = tendon force.

If the anchor is not cylindrical (as with an anchor formed with high pressure grout), analysis is much more difficult.

2.1.3.3.2 Grout-Tendon Bond Design

According to Xanthakos (1991), grout prevents a tendon from slipping by three processes: *Adhesion*, the "sticking" of grout particles to the tendon; *friction*, between the surfaces of the grout and tendon; and *mechanical interlock*, which occur at locations where the tendon is twisted, bent, ribbed, etc. Spiraling of the tendon caused by the helical arrangement of the wires in the strand results in a small increase in resistance to slipping. An increase in grout strength increases the bond strength by about 10 percent for every 7 MPa (1000 psi) in the strength range of 16 to 52 MPa (2300 - 7500 psi). Increasing the confining stress of the grout results in a linear increase in resistance to pullout as demonstrated in an experiment where the confinement was increased from 0 to 17 kN/m² (2.5 psi) and an increase in strength observed.

Typical code values for minimum embedment length (length of tendon in contact with grout) are 3 m (10 ft) for tendons bonded in situ. For tendons which will have shorter embedment lengths, tests should be conducted.

In general, a grout cover of 20 mm (3/4 in) should be maintained, and the cross-sectional area of the tendon should always be less than 15% of the cross-sectional area of the borehole.

2.1.3.3.4 Corrosion Considerations

Grout may be corroded by soil and/or groundwater. In addition, the tendon steel may be corroded by grout. This section discusses these two cases.

2.1.3.3.4.1 Corrosion of Grout

Littlejohn (1986) lists some ways that grout may be corroded by soil and/or groundwater, based on how concrete may be corroded. Sulfates may be present in the soil, groundwater, or both and are very corrosive to grout. The extent of corrosion which may occur depends on the quantity and composition of sulfate present, amount of groundwater present and its seasonal fluctuations, the construction method, and the type and quality of grout used. If contact with sulfates is unavoidable, a low-permeability and/or dense grout must be used. National codes may be consulted for specific recommendations regarding mix design.

Acids may also corrode grout. However, this is not usually a problem since groundwater pH is usually above 5.5. If the pH is between 3.5 and 5.5, grout should be designed to be dense and/or should have an admixture to prevent corrosion. For pH below 3.5, a grout specifically designed to resist corrosion should be used.

2.1.3.3.4.2 Corrosion of Tendon by Grout

The alkaline nature of grout (pH equal to about 12.6) provides excellent protection to a tendon by coating it with a film that retards future corrosion as well as providing a physical

barrier. However, if this pH should fall (by contact with acidic gases in the atmosphere or acidic groundwater), the protection could be lost. The presence of aggressive ions such as chlorides in the grout may hasten corrosion. Porosity of the grout, as well as cracks which may develop over time, may allow a corrosive combination of substances such as oxygen, moisture, and aggressive ions to contact the tendon. These factors should be considered when choosing a grout mix design.

2.1.3.4 Anchor Head

The function of the anchor head is to transfer the load from the tendon to the structure. Design of anchor heads is generally performed by manufacturers. Therefore, only a general description of anchor heads will be presented. First, an introduction to anchor heads is provided, followed by a discussion of corrosion prevention.

2.1.3.4.1 Introduction

The transfer of loads from the tendon to the retaining wall is accomplished via a structure which holds the wires and a plate which distributes the load so as not to damage the structure. Usually the anchor head as well as the tensioning equipment is the same as that used for prestressed concrete. Specific information is available from the manufacturers. A common design is to have the individual wires or strands secured by wedges or cones placed in a tapered hole as illustrated in Figure 18. As the tensioning occurs, the wedges or cones are forced into the hole, pinching the wires and locking them into place. Anchor heads are designed so that the load is applied centrally at all times to ensure adequate load transfer. Xanthakos (1991) suggests a tolerance of ± 5 mm (0.2 in) and that wedges be secured at the same tolerance to prevent unequal loading (Figure 19).

Design is basically a process of selecting a suitable anchor head based on data from the manufacturer. Xanthakos (1991) suggests that, depending on the specific anchor system, the anchor head may need to be designed so that the stress can be applied at 80-90% of the characteristic strength and that it should be capable of tolerating adjustments in tension either up or down. The anchor head should allow wires to be stressed simultaneously but locked off individually, and should be designed so that it may be lifted to check tension and subsequently reseated.

2.1.3.4.2 Corrosion Protection

Corrosion of the anchor head can be a critical concern. Since the anchor head is usually exposed directly to the elements, special care must be taken to provide protection against corrosion.

Corrosion protection for anchor heads may not be applied at the factory since the tensioning process must occur on site. Furthermore, since a successful lock-off is dependent on the anchor head gripping the wires, the wires must be cleaned thoroughly, a process which removes any corrosion protection which may have been in place. Steps must be taken to protect the portion of tendon on *both sides* of the bearing plate as well as the locking hardware and bearing plate itself.

Figure 20 illustrates a typical corrosion protection scheme. Cement grout is generally not accepted as a corrosion protection method for the inner head, that portion of wire which is between the free length and the bearing plate, since grout may crack. A ductile material such as

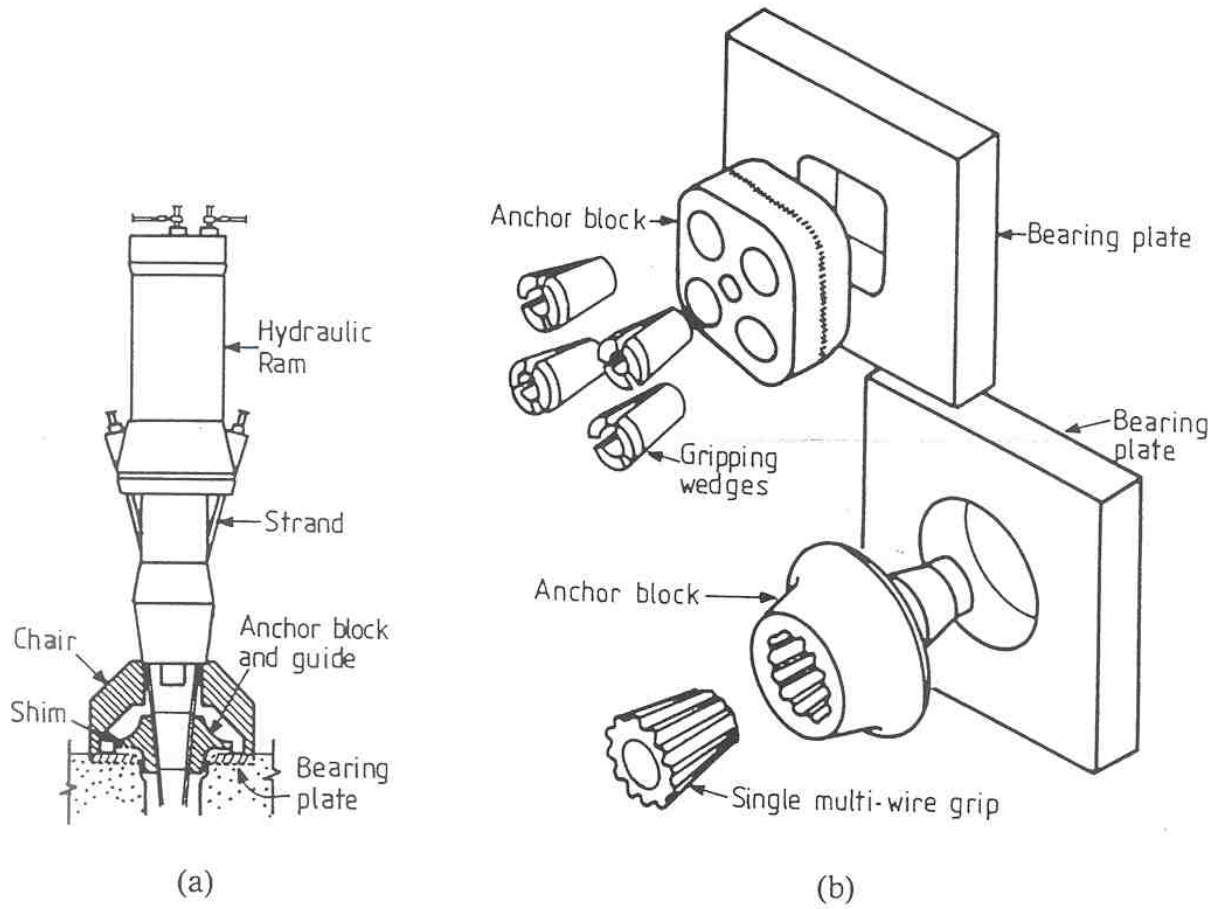


Figure 18. Tendon tieoff details (from Hanna 1982)

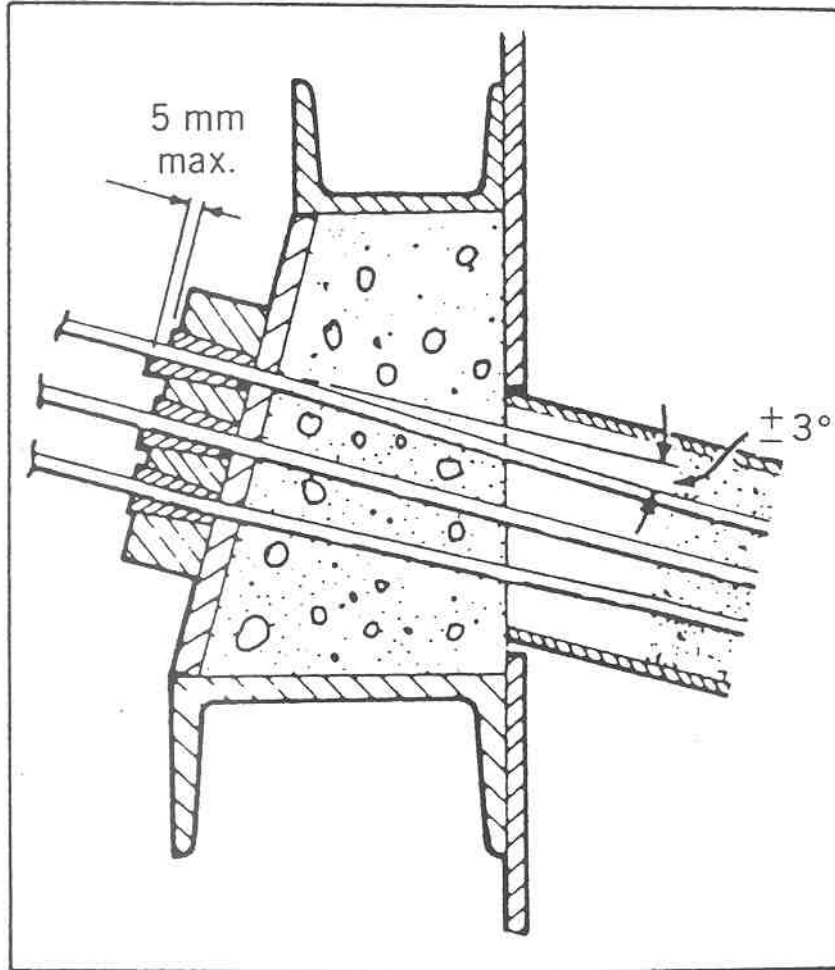


Figure 19. Recommended tolerances at anchor head (from Xanthakos 1994)

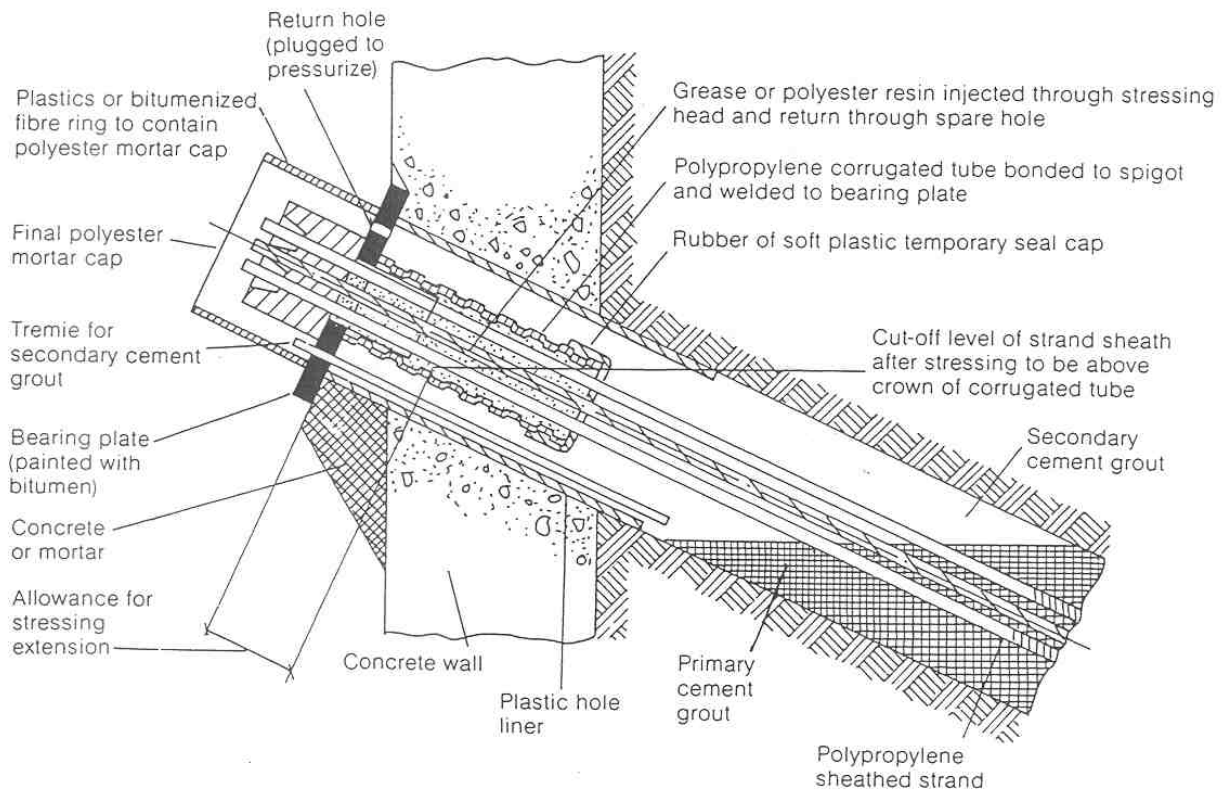


Figure 20. Typical anchor head detail for double protection of strand tendon (from Littlejohn 1986)

grease is generally used, and the mechanism is capped with a seal. In wet conditions, the space may be filled via injection and vent hole to ensure that all materials in the voids are completely removed.

For the outer head, which includes the locking mechanism, corrosion protection depends on whether the tendon is designed to be retensioned. If so, the protection must be easily removed. Grease along with a steel or plastic cap is commonly used. If the anchor is designed not to be retensioned, more permanent sealants such as resins may be used. If the design calls for the anchor head to be completely enclosed in concrete, a cover of 30-60 mm (1.2-2.4 in) is adequate.

The bearing plate must be protected as well. This is accomplished most often by painting the surface with protective materials after the surface has been thoroughly cleaned. Bearing plates may be seated on concrete by concrete, cement, resins, epoxy, or polyester mortar or directly on steel plates. Regardless of which protection method is chosen for the bearing plate, it must be compatible with the protection selected for both the inner and outer anchor head.

2.1.4 Number, Spacing, and Orientation of Anchors

The location of anchors was discussed in Section 2.1.4, where it was determined that anchors should be located well behind the failure plane. The number of anchors which should be used and how the anchors should be spaced along the wall are discussed in this section.

2.1.4.1 Horizontal and Vertical Spacing and Number

Horizontal and vertical spacing of ground anchors are usually governed by structural and construction concerns in conjunction with the optimum anchor loads. Once a spacing scheme has been proposed, verification must be made that the scheme meshes well with the construction schedule. For example, if the wall is to be constructed "top down" (i.e., excavated beginning at the ground surface and proceeding downward), the vertical spacing must correspond to expected excavation levels. Other construction considerations include loads produced by the equipment itself and the possibility that site access may limit the spacings that may be accommodated.

The primary consideration is the structural integrity of the wall. The anchors must be spaced so that the wall (or portion of the wall) remains structurally safe at all times when all forces, including construction loads, are applied. Anchors are in effect point loads and should be positioned to ensure that all forces and overturning moments are balanced.

The type of wall can affect the spacing as well. Walls may be constructed as continuous structures or modular components, and the anchors must be placed so that components are adequately supported. Regardless of the type of wall, the design load of the anchor itself must not be exceeded at any time.

A final consideration is the location of the ground anchors themselves. Anchors spaced too closely together on the wall may result in anchors which are spaced too closely together in the ground. This reduces the anchor capacity. The radius of stressed soil which surrounds the soil may be considered to be approximately three times the radius of the anchor itself; typical values range from 2 to 3 m (6 to 9 ft) (Xanthakos 1991). If the anchors are too close to one another, they lose capacity since the zone of influence of each anchor overlaps with that of other anchors. The area of soil influenced per anchor decreases, resulting in lower capacity per anchor.

The construction tolerances must also be considered as well. If anchors will overlap, vertical staggers (via varying the inclination) or horizontal staggers (varying the length) may be used to mitigate the overlapping problem.

2.1.4.2 Orientation

Ground anchors are usually angled downward from the horizontal. The primary reason is to better accommodate installation (Section 2.2). Often this is required to avoid obstructions such as foundations of adjoining buildings or utilities. The inclination angle may need to be adjusted to reach suitable ground conditions such as a favorable rock layer. Varying the angle of anchors may prevent the overlap of stressed soil conditions from adjacent anchors.

According to Xanthakos (1991), the practical minimum angle is 15° below horizontal, with angles of $15\text{-}30^\circ$ being the most common. In cases where the ends of the anchors need to be exceptionally deep (greater than 10 m or 35 ft), an angle of 45° or more may be used. However, increasing the angle of inclination decreases the horizontal force exerted by the anchor (thereby reducing its effectiveness at supporting the wall) and increases the vertical force (resulting in more force which must be supported by the base of the wall).

2.1.5 Shear and Moments in Wall

The use of tiebacks introduce high shear stresses into the retaining wall which is being supported. Because there are high moments between tiebacks, long spans between tiebacks are not advised in either the vertical or horizontal direction. The magnitude of the shears and moments will dictate most of the design of the wall facing, including amount of reinforcing steel, section modulus of walers, timbers and beams, and the thickness of shotcrete. Also, punching failure at the tieback must be checked to insure that the tieback does not pull out of the wall.

2.1.6 Drainage

Drainage of water from the backfill behind a retaining wall is discussed in this section, with subsections devoted to the need for drainage and to common methods of providing drainage.

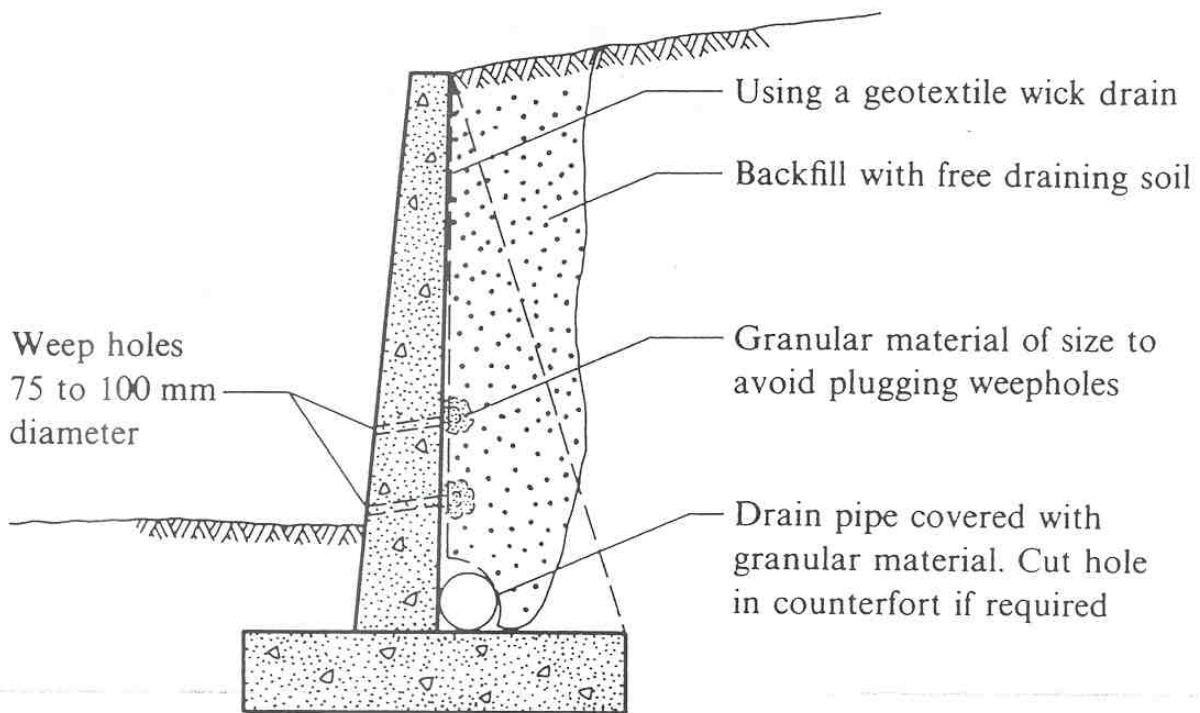
2.1.6.1 Need for Drainage

There are two primary reasons for providing adequate drainage for a retaining wall. First, allowing water to collect behind a wall greatly increases the force acting on the wall. Providing drainage is cheaper and easier than designing the wall to support this added force. Second, proper drainage can prevent erosion of the backfill and loss of backfill geometry. Drainage avoids soil saturation which weakens the soil and increases the soil force on the wall.

2.1.6.2 Common Drainage Methods

One method of providing drainage for a retaining wall is a system of pipes (Figure 21). A sloping collection pipe is installed on the backside of the base of the wall, parallel to the wall. The perforated pipe collects water and carries it to the ends of the wall where it is drained away from the face of the wall.

Another scheme uses "weep holes" which are placed through the wall. If the base of the wall is deep underground, the weep holes are placed at the ground surface. The weep holes allow the water to pass through the wall and be routed away from the wall foundation.



If weepholes are used with a counterfort wall at least one weep hole should be located between counterforts

Figure 21. Drainage schemes for retaining walls (from Bowles 1988)

Water which collects below the ground surface will most likely have equal depths on both side of the wall, providing equal force on either side. However, this water will weaken the foundation soils and should be drained if possible.

The major problem with using this method is that soil particles can clog the weep holes. To prevent this, a filter must be used.

Graded soil filters are commonly used. Gravel is placed around the weep holes, and the backfill of decreasing size is placed *and compacted* until the size of the primary backfill is reached. Inspection of construction is critical, as contractors may simply dump the primary backfill type behind the wall and not take time to backfill larger material around weep holes. Criteria for choosing the soil filters are in Table 1. A more complete discussion of granular filter design is given in Terzaghi and Peck (1967).

Geotextiles or geosynthetic composites may be used for filters/drains. They are placed vertically along the rear face of the wall. Water may then run vertically and horizontally until it encounters the geosynthetic, which channels it to the weep hole or other exit. The geotextile openings must be selected so the soil does not clog or pass through the geotextile. A detailed design procedure for geotextile filters is described by Luetlich et al (1992).

Table 1. Soil filter criteria (from Terzaghi and Peck 1967)

Character of Filter Materials	Ratio R₅₀	Ratio R₁₅
Uniform grain-size distribution (U = 3 to 4)	5 to 10	-
Well graded to poorly graded (non-uniform); subrounded grains	12 to 58	12 to 40
Well graded to poorly graded (non-uniform); angular particles	9 to 30	6 to 18
$R_{50} = \frac{D_{50} \text{ of filter material}}{D_{50} \text{ of material to be protected}}$	$R_{15} = \frac{D_{15} \text{ of filter material}}{D_{15} \text{ of material to be protected}}$	

Notes: If the material to be protected ranges from gravel (over 10% larger than No. 4 sieve) to silt (over 10% passing No. 200), limits should be based on fraction passing No. 4. Maximum size of filter material should not exceed 3 in. Filters should contain not over 5% passing No. 200. Grain-size curves (semi-logarithmic plot) of filter and of material to be protected should be approximately parallel in finer range of sizes.

A method of drainage which may be used in conjunction with weep holes is a drainage swale which is placed at the ground surface at the top of the wall. This swale, lined with an impervious material and sloped, serves to reduce the amount of runoff that percolates into the backfill.

2.2 Installation

This section discusses the procedures for installation of an anchored retaining wall. The first subsection (Section 2.2.1) covers anchor installation, beginning with drilling of the borehole. Tendon installation is discussed next, followed by grout placement, construction limitations, prestressing of the tendon, and prooftesting to confirm the integrity of the anchor system. The second subsection (Section 2.2.2) briefly discusses construction of primary types of retaining walls which are used with anchors.

2.2.1 Anchors

This section details the installation of ground anchors. First, the three primary steps of installing an anchor are discussed: drilling the borehole, installing the tendon, and placing the grout. Next, some general limitations of the installation of anchors is given. Prestressing, the process of tensioning the anchor, is detailed next. Finally, prooftesting the anchor, both before and after installation, is discussed.

2.2.1.1 Drilling

The first step in installing an anchor is drilling the hole. Drilling should always be performed by a competent contractor and must be checked with adequate on-site inspection. Although the majority of anchor failures are attributed to factors other than faulty drilling, the drilling process can lead to a failure and therefore should be given careful consideration.

The primary determinant of drilling efficiency (and hence overall cost) is ground conditions, but other factors play a role as well. Factors to consider first are site conditions such as soil composition, accessibility, topography, and construction restrictions. Other important criteria include hole geometry and size; scope of the drilling required, anchor type and expected load, flushing medium, and local labor costs (Xanthakos 1991 p. 52-53). The best method of estimating drilling rates is by obtaining data regarding drilling rates in similar soil.

Constructability affects the selection of a drilling method as well. Direction of drilling may range from near horizontal to near vertical downward and occasionally inclined upward. Other considerations include disturbance to surrounding soil, hole stability, borehole wall stability, and groundwater infiltration. To monitor these factors adequately, the drilling method should allow monitoring of the process so conditions such as unexpected soil types may be detected. Observations of the drilling rates can provide clues to ground variability.

2.2.1.1.1 Drilling Methods

The primary determinant of drilling method is the material to be drilled, i.e., soil or rock. Major types of drills include percussive, rotary, and percussive-rotary. Diamond drills are available but create a hole with extremely smooth sides which lowers the capacity of the anchor by reducing friction force. Diamond drilling is expensive. Blasting with explosives is also occasionally used.

Percussive drills act by striking a chisel or wedged-shaped bit repetitively. The striking action breaks up hard material and allows it to be flushed out of the hole. The striking head may be located above ground (which allows holes of up to 125 mm or 5 in. in diameter) or down-the-hole (DTH) directly above the bit (holes up to 750 mm or 30 in.). Percussive drills are primarily used in rock boring.

Rotary drills are used in soil. They work through the cutting action of a rotating bit and axial thrust of the bit into the hole. These augers are usually used in self-supporting materials in which a hole may be drilled without collapse. Standard continuous flight augers carry the soil out along the auger flights. Hollow stem augers allow material to be placed down the hole through the center of the auger without removing the auger from the hole. These are often used in flowing or squeezing soils. Holes of diameters ranging from 150 to 600 mm (6 in. to 24 in.) may be bored using rotary drills.

Rotary-percussive drills combine the mechanisms of percussive and rotary drills. Rotation is less than with rotary drills but more than percussive, while percussion is lower than percussive drills but more than the rotary types.

Blasting is rarely used. The use of explosives is not popular because of the possibility of damage to surrounding soil, safety, uncertainties regarding amount and placement of explosive, and the difficulty in obtaining consistent results.

The first step in selecting a drill type is to determine the site conditions, size of the hole required, and anchor capacity. Percussive drills are recommended for rock when diameters are up

to 100 mm (4 in) and depths are less than 60 m (200 ft). Rotary drills are preferred for deeper holes or poor rock conditions. Rotary drills with an eccentric bit are best for rock which has layers of hard and soft material. Percussive drills with DTH heads are less prone to jam but are much more expensive to repair if jammed. Finally, rotary tools are preferred in urban areas since they cause less disturbance to surrounding areas and are quieter. Table 2 details various types of drilling equipment and provides guidance on selection.

Anchor boreholes will typically range from 75 to 150 mm (3 to 6 in) in diameter. If the soil tends to collapse, a casing is installed as the hole is drilled and then removed as grout is placed. Methods which do not require a casing have been developed, but their use is restricted to situations where access is not limited, soil conditions are not difficult or highly variable, and the area is relatively undeveloped so that possible undermining caused by removal of excess soil is unlikely to cause damage.

Estimating the drilling rates is important with regard to estimating construction time. For percussive and rotary-percussive drilling, one simple test to help estimate the drilling rate involves dropping a weight on a rock sample and screening the sample. Other methods relate drilling rate to rock properties such as texture, hardness, breaking characteristics, and geologic structure. Table 3 relates drilling rate in various rock types to that of Barre granite, a homogenous, solid rock. The one consistent factor in drilling rate determination is that a solid, homogenous rock results in a faster rate than one with faults and inconsistencies. In highly faulted rock, extreme care must be taken to prevent loss of the flushing medium and jamming of the bit, which may result in damage to the bit.

The accuracy with which holes are placed depends upon anchor spacing. If spacing is wide (> 2 m or 7 ft), some leeway is allowed. However, if anchor spacing is close or there are obstructions such as boulders or underground utilities, low tolerances are required. The two main sources of error in hole placement are incorrect initial placement of the drill and deviations which occur as the hole is being drilled. Proper location of the drill rig may be ensured by the use of spirit levels and profiles. Errors which occur during drilling may result from thin drill rods, excessive thrust, and fissures in the rock. Boreholes which are nearly horizontal may cause the drill rod to sag under its own weight, turning the bit upward and producing an arched hole. Although a wide range of tolerances are quoted in both codes and other references, Xanthakos (1991) recommends angular tolerances of $\pm 2^\circ$ for widely spaced anchors (spacing > 2 m or 6.5 ft) and $\pm 1^\circ$ for closely spaced anchors (spacing < 2 m or 6.5 ft).

2.2.1.1.2 Flushing

Rock and soil particles produced during the drilling process must be removed from the borehole quickly and efficiently. Three common methods are the use of air, water, and a bentonite slurry.

Air is very efficient but is most useful in very dry conditions. In addition, it produces dust particles which may be harmful in a confined space.

Water is most effective in sticky clayey soils. It also cleans the sides of the borehole to improve the grout-ground bond. However, water may further weaken soft rocks such as marls, chalk, and fissured shales.

Bentonite slurries are not used often. They are very effective at keeping particles suspended and effectively removing them. In addition, the slurry keeps the hole from collapsing.

Table 2. Choice of drilling method and machinery to fit pertinent conditions

	Percussive (A)	Percussive (B)	Percussive (C)	Rotary (D)	Rotary (E)
Drill String	Standard coupled rods, separate anchor	Coupled rods also act as anchor	Coupled drill tubes and rods used simultaneously from same drive adapter Atlas Copco OD method	Coupled flight augers	Standard rotary drilling tubes
Drilling Machine	Wagon drill with drifter or crawler drill with independent rotation drifter, compressed-air-powered	Wagon drill with drifter or crawler drill with independent rotation drifter, compressed-air-powered	Special independent rotation drifter mounted on heavy-wheeled chassis or crawler, compressed-air-powered	Standard auger drill capacity of torque and pull down dependent on hole size and depth; Diesel-hydraulic power; chassis powered wheel or crawler designed for drilling of shallow angle holes; wheeled or skid mount possible	Rotary rod drill or diamond drill; performance about 2000 ft-lb torque, 5 ton pulldown 0-500 rpm; diesel-hydraulic power; chassis-powered wheel or crawler designed for drilling of shallow angle holes; wheeled or skid mount possible
Suitable Strata	Self supporting rock; only few feet of overburden possible with aid of stand pipe	All materials	All materials provided drill tubes are uncoupled when rock is encountered and drilling continued alone with rods	All self-supporting soft material such as clay and chalk; not rock; not non-self-supporting material such as sand and gravel unless casing is used	All soft materials such as clay, sand, and gravel; also soft and medium rods; not hard rock
Anchor	Multistrand rope or single rod	Special coupled rods	Multistrand rope and single rod	Multistrand rope most common; single rod also possible	Single rod most common as in Bauer system; multistrand rope possible where ground is self-supporting
Flushing Media	Normally air, but water could be used	Invariably water but air occasionally useful	Water; air used very rarely	None	Water; air used very rarely

Table 3. Drilling rate index for various rocks (from Xanthakos 1991)

Characteristics	Comparative Drilling Speed ^a	Rock Material
Hardness--1-2 Texture--loose Breakage--shatters	1.5	Shales Schist Ohio sandstone Indiana limestone
Hardness--3-4 Texture--loose grained to granitoid Breakage--brittle to shaving	1.0-1.5	Limestone Dolomites Marbles Porphyries
Hardness--4-5 Texture--granitoid to fine grained Breakage--strong	0.6-1.0	Granite Trap Rock Most fine-grained igneous Most quartzite Gneiss
Hardness--6-8 Texture--fine grain to dense Breakage--malleable	0.5	Hematite (fine-grained, gray) Kimberly chert Taconite

^a Barre granite is used as the standard for determining a comparative drilling speed of 1.0 because of even texture, hardness, and consistent drilling.

A flushing medium may be introduced through the drilling rod and bit and return in the space between the rod and sides of the borehole in a process known as "normal circulation." This removes cuttings from the borehole. "Reverse circulation", in which flushing fluid follows the opposite circulation path, may also be used.

Regardless of the method, holes should be extended at least 0.3 to 0.7 m (1 to 2 ft) at the bottom as a sump for collection of debris. Once a hole has been flushed, a sounding should be made to insure that all debris have been removed. If the hole is clean, the top of the hole should be plugged to prevent contamination. Drill spoil should be monitored for changes in soil and groundwater conditions.

2.2.1.1.3 Water Testing of Borehole

Boreholes in rock must be tested to insure the water-tightness and preclude the presence of fissures. Fissures in the rock can lead to grout loss and consequently to reduced capacity and increased risk of corrosion. The test is performed by flushing the borehole until the outflowing water is clear. The test is then performed using either a falling head test or a packer test which allows testing over certain segments of the hole. Experiments generally conclude that a 160 µm fissure will result in grout loss.

If the flow of water from the hole exceeds 3 liters/min/atmosphere (0.05 gal/min/psi), pregrouting is necessary. However, if multiple fissures are known to exist, the critical flow may be adjusted accordingly. The level of groundwater should be monitored closely to determine its effect on the head. Finally, the head should not be too large as it can cause small fissures to open up, falsely signaling the need for waterproofing.

If waterproofing is necessary, it is accomplished by grouting the hole and then drilling it again, usually within 24 hours. Another water test is performed, and the process is repeated if the

results are still not satisfactory. If there are large or numerous fissures, pressure grouting may be required. The grout used should be similar to that to be used for the anchor itself. Use of chemical grouts should be cleared with the design engineer to insure that corrosion protection of the tendon will not be compromised. Finally, pregrouting may not be necessary if the grouting process to be used for the anchor will accomplish waterproofing as well.

2.2.1.2 Tendon

The tendon is the next anchor component to be installed. This section discusses the storage, handling, and installation of wire strand tendons.

2.2.1.2.1 Storage and Handling

Tendons, along with all other components of an anchor system, should be stored properly in a clean environment under conditions not conducive to corrosion. An ideal location is indoors. However, if tendon steel must be stored outdoors, it should be stacked off the ground and covered by a waterproof tarpaulin. The tarpaulin should be secured so that air may circulate through the stack. If the humidity is above 85%, the tendons *must* be protected with wrappings which prevent contact with the moisture laden air since humidity levels above 85% are known to cause rapid and severe corrosion. Coils of anchor wire typically have a diameter of at least 200 times the diameter of the wire.

A normal coating of rust may actually improve the grout-tendon bond, but loose rust should be removed prior to installation. Any tendons which show signs of pitting, kinks, or twists should be rejected. Tendons should not be dragged across any abrasive surfaces, including the ground, before installation to prevent damage to the corrosion protection system. They should also be protected from contact with damaging materials such as weld splatter.

2.2.1.2.2 Installation

First, wires are cut to the proper length, and sharp edges at the cut are smoothed before assembly. Corrosion protection is removed in the fixed length and the tendons are cleaned. This may necessitate the unraveling of the individual strands to ensure proper removal of grease and other materials which could reduce the bonding capability. A protective cone may be placed at the end of the tendon to protect it during handling and installation and to prevent damage to the side of the borehole during installation.

Centralizers and spacers are installed next. Centralizers keep the wires centered in the borehole for uniform placement and grouting. Spacers are used to keep individual tendons parallel to each other and to prevent tangling and contact between tendons. A distance of at least 5 mm (0.2 in) is usually maintained between tendons. Tangling or contact may result in high stress concentrations and subsequent failure. These spacers, a detail of which is shown as Figure 22, are typically spaced 4 to 8 m (13 to 26 ft) apart in the free zone and half of that in the fixed zone. Also, centralizers and spacers must be chosen so that they do not enhance corrosion of the tendons and vice versa. Lubrication should be used at the points where the tendon contacts the centralizers or spacers to prevent friction build-up during stressing.

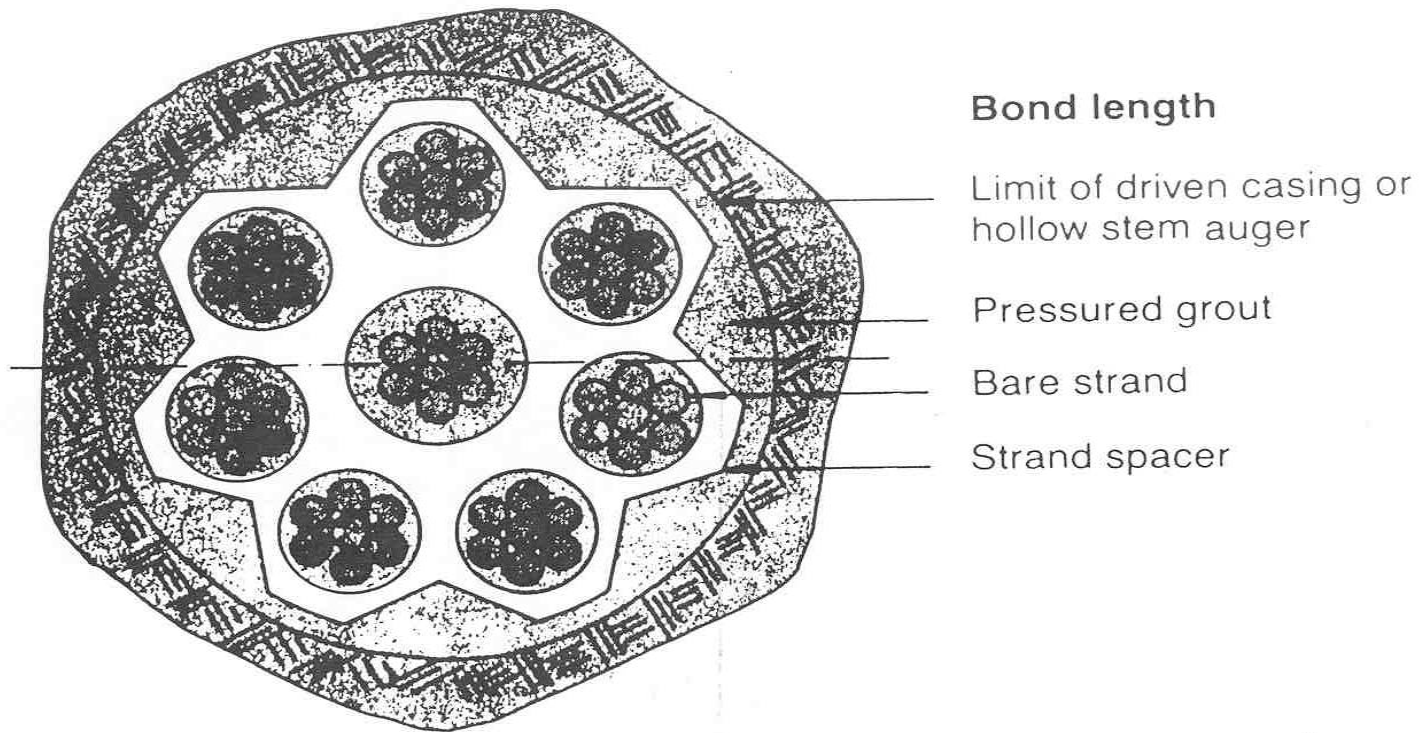


Figure 22. Tendon centralized details (from Xanthakos 1994)

In the fixed anchor zone, the spacers serve to ensure uniform grout cover both outside and inside the tendon assembly and to prevent contamination of the tendons by materials on the side of the borehole. Spacer assemblies may even be designed so that the tendons produce "waves" in the grout which enhances the tendon-grout bond.

The actual process of placing the tendon in the borehole is known as "homing." Homing should be scheduled as soon as possible after drilling is completed since an open borehole may allow degradation of the soil or rock to occur. If the ground is subject to swelling, installation should be rapid. If immediate installation is not possible, the hole should be plugged.

As the first step in homing, the tendon is inspected carefully for damage both to the wire and to the corrosion protection. Next, the tendon is lowered into the hole. Any method which allows a controlled lowering of the tendon may be used, but mechanical methods are preferred if the tendon weighs in excess of 200 kg (440 lb). A funnel shaped structure may be used for homing into a cased borehole to prevent contact of the tendon with the sharp edges at the entrance of the casing. In the initial stages (or periodically if large numbers of tendons are being installed), one tendon should be extracted after homing to inspect for possible damage as well as to gauge the effectiveness of the centralizers and spacers.

2.2.1.3 Grout

There are two basic methods for installing grout: two-stage and single-stage.

Two-stage grouting involves placing the grout in the anchor zone first. Then, the free bond zone is filled with grout after the tendon is stressed and tested. In rock, the primary grout may be placed before or after the homing process, but placement after homing is recommended for large tendons and poor rock and is the only option for shallow holes or anchors with an upward inclination. If the grout is placed before homing, homing should be initiated within 30 minutes.

The fixed anchor zone is typically constructed 2 m (7 ft) longer than is necessary to develop sufficient frictional resistance. This helps to prevent cracking of the grout during stressing. Secondary grouting is usually performed with a grout of the same composition as that used for primary grouting. However, anchors in North America generally employ the use of sand, rock, or weak grout as secondary grout to allow free movement of the tendon for possible future retensioning.

Disadvantages of two-stage grouting include the formation of a joint where the primary and secondary grout meet; this can become a pathway for corrosion. Grout may escape to the ground which makes determination of the grout volume which composes the fixed anchor length difficult. Finally, the process is very time-consuming and laborious.

In single stage grouting, the entire length of the borehole is filled in one step. The free length of the tendon must be carefully greased to ensure that the grout-tendon bond forms only in the fixed length.

Injection of the grout always proceeds from the lowest point of the borehole. Provisions must be made to vent air and water from the rear of the borehole if the anchor is inclined upward. Grout is pumped at a constant rate into a pipe to the bottom of the borehole. As placement proceeds, the pipe is withdrawn slowly at frequent intervals. Since air must not be introduced during grout placement, all pipe joints should be checked for leaks prior to grouting. The pipe should not be lifted above the grout for any reason during placement. If grouting is interrupted, the grout must be removed via flushing or re-drilling and the process begun anew.

There are no general guidelines regarding the proper grouting pressure to be used. Specialty contractors generally choose the pressure to be used, and these pressures may be confirmed with a test trial prior to installation. High pressures are most useful in fractured rock or soil and are not required in high quality rock. A typical pressure range is 0.30 to 0.70 MPa (45 to 100 psi), and a practical upward limit is 3 MPa (435 psi). In addition to providing no clear-cut benefits, excessive grout pressures may disturb surrounding soil and cause damage both to adjacent anchors and surrounding utilities and structures.

2.2.1.4 Construction Limitations

Before the discussion of installation procedures is continued, a brief summary of the limitations of anchor construction is provided. Although in theory anchors may be installed in any soil or location, there are practical limits. For example, soft or organic soils and fissured rock may preclude anchor installation. Soft soils such as very fine sands and silts, clay shales, marls, and chinks which are subject to softening during drilling may require special methods, such as chemical grouts or extra diligence during flushing, in order for anchors to be viable. Long boreholes cause numerous problems, including limitations of the drilling machine and difficulty in properly homing the tendon. Finally, site access may hamper construction, particularly in areas with steep slopes or high levels of congestion. Any of the factors mentioned above may add significantly to the cost of the anchor and contribute to lower anchor capacity.

2.2.1.5 Stressing

After the tendon is in place and the grout has cured for at least 24 hours, the tendon must be stressed. This serves a dual purpose. First, it insures that a known load is provided by the anchor. Secondly, it allows testing of the anchors to guarantee that the required capacity has been developed.

2.2.1.5.1 Methods

The first step in stressing the tendons is to check to insure that the tendons have not become crossed in the borehole. Properly designed centralizers and spacers will help to reduce this risk. Stressing of tendons is usually performed by a direct-pull method utilizing a hydraulic jack. All strands comprising a single anchor are stressed simultaneously. Figure 23 shows a typical jacking assembly of this type. However, this may lead to unequal forces in each of the tendons which can become a problem in short anchors since small differences in elongation will result in large discrepancies in total load on the strand. A procedure which stresses only one strand at a time may be used. However, this system has problems--a second round of tensioning must be performed to equalize the forces in all tendons.

A bearing plate must be placed on the ground unless a rigid structural member is available. This plate must be normal to the stressing direction and should experience no more than 1 mm (0.04 in) of deformation. Care must be taken to ensure that the attachment of the tendon to the jack is adequate, and safety precautions must be implemented to protect personnel in the event of failure of the jack and/or anchoring assembly.

For practical reasons, the elongation of the tendons must equal at least 30 mm (1.2 in) to allow the cables to be removed from the locking wedges on the jack. The required stress level is determined as the service load plus calculated losses. These losses result from slippage of the

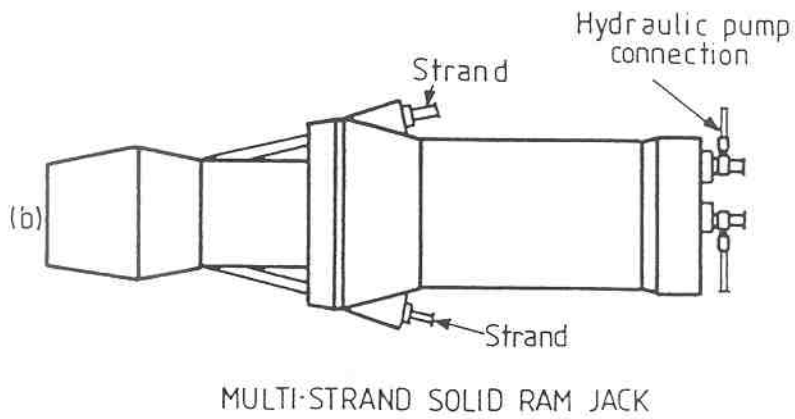
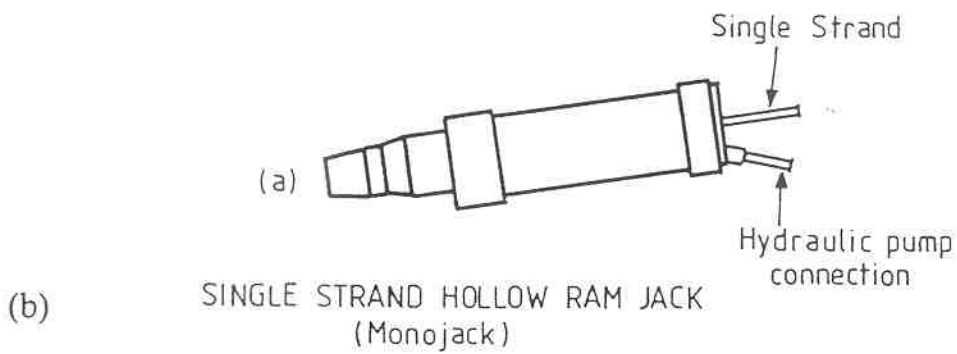
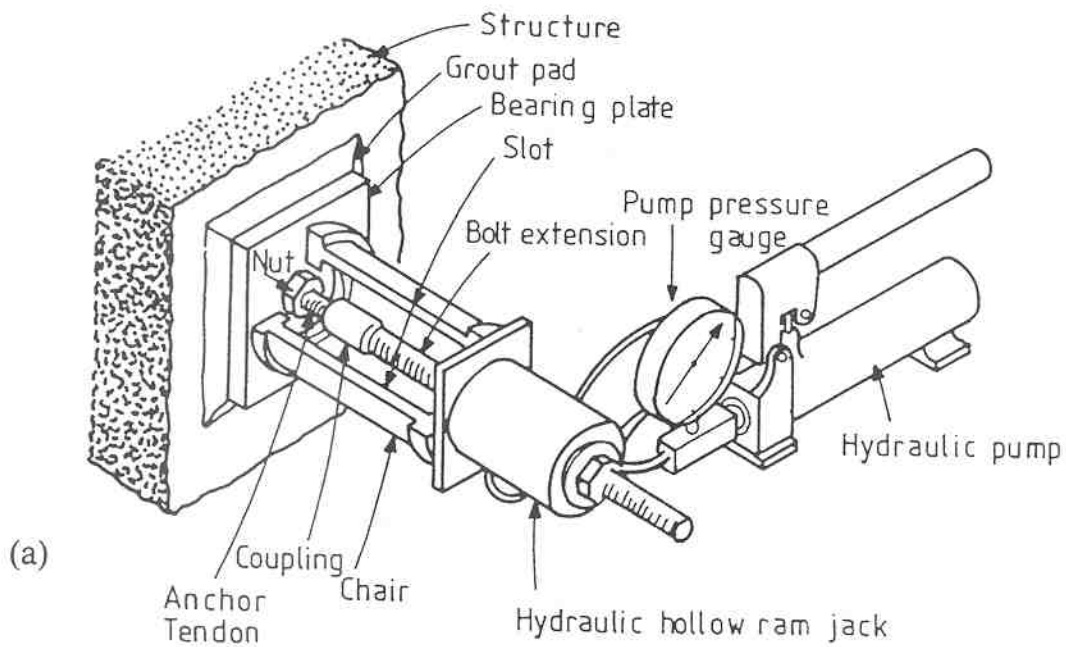


Figure 23. Anchor stressing details (from Hanna 1982)

tendon in the anchor head assembly and losses from relaxation of the steel and creep of plastic soil, friction in the jack (about 2-3% of the load), frictional losses in the anchorage device (4-5%), and typically small losses due to inconsistencies in the bore hole and/or sheath (2-3%). Another source of stress loss is due to factors which are difficult to quantify such as bonding and accidental losses (from faulty tendon alignment, for example).

After the tendon is stressed to the required level (as measured by load cells and other methods discussed in Section 2.3.1.1) the tendon is "locked-off," or secured, in the anchor head assembly.

2.2.1.5.2 Load Monitoring

The two parameters which are necessary to adequately evaluate the anchor are load and extension. Typically, load is measured via gages which monitor the pressure of the hydraulic fluid in the jack. The gages should be compared often to a control gage. If a difference of more than 3% exists, the jack gage should be replaced. Measuring devices used to check the stress should be sensitive and calibrated often. Hobst and Zajíc (1983) suggest that instruments be calibrated at the start of the stressing operation, and then once a month or after every thirtieth installation. Even with appropriate calibration, errors are often quite large and can be up to 15%, although the average is about 5% (Hobst and Zajíc 1983).

Displacements are measured relative to a fixed reference point such as a rod driven into the ground or a steel tripod. If placement of a fixed point is not possible, movement of the jack may be used. The retaining wall should not be used as a reference point since the stressing of the tendon may cause movement of the structure.

There are no set standards for the number of readings to be recorded. However, detailed records should be maintained for every stressing operation. Figure 24 shows one example of a data sheet.

More information regarding the analysis of the data collected during load monitoring is given in Section 2.3.

2.2.1.6 Prooftesting

Anchors must be tested to insure that they meet the design criteria. On-site testing is generally performed in the early stages of design to determine the bearing capacity of the ground and to provide assurance that the use of anchors is feasible.

After construction is completed, anchors are always tested at the time of stressing. This testing serves several purposes. The primary ones are to confirm that the anchor can support the design load and to confirm its behavior under loading. The actual factor of safety may be determined if the anchor is stressed to more than the design load as is often the case. Results of anchor tests are compared to predetermined acceptance criteria. Perhaps most importantly, any serious errors in design or construction may be discovered before a dangerous situation occurs.

This section details the types of tests that are commonly performed. First, a brief discussion of the stresses which are applied during the test is given. Then, the four basic types of tests (precontract, acceptance or proof, on-site suitability, and creep) are explained. Finally, general considerations regarding the development of a testing program are provided.

ANCHOR STRESSING RECORD

Project Anchor No. Date.....
 Date Grouted.....

Equipment Data Jack Type Piston Area Stroke Pump Type Maximum Pressure Pressure Gauge No..... Date of calibration.....	Anchor Data Type Steel Details..... Supplied by..... Strength..... Area of tendon steel..... Modulus of Elasticity..... Fixed length..... Stressing length (incl. jack)..... Length of anchor hole..... Length of anchor tendon..... Diameter of anchor hole.....
---	---

STRESSING DATA

Pressure gauge reading	Corrected pressure	Force	Extension Data			Date.....
			Reading	Extension	Total Extension	Calculated Notes

Strand extension in jack.....
 Pull-in of wedges.....
 Extension at lock-off.....
 Data on lift-off/restressing.....

Figure 24. Anchor stressing log (from Hanna 1982)

2.2.1.6.1 Stressing Forces

Applicable codes are typically followed with regard to the amount of force to which the anchors are subjected during testing. However, a critical criterion is that the tendons not be overstressed. To insure this, factors of safety are used when determining the testing loads. In addition, factors of safety in testing allow for errors which may have occurred in estimation of the design load and to allow for the possibility of the failure of an individual anchor which increases the load on the remaining anchors.

The testing loads are classed according to whether the installation is temporary or permanent (Hanna 1982). For temporary anchors, the working load should not be more than 62.5% of the characteristic tensile strength (f_{pu}), and the test load should be limited to 80% f_{pu} . For permanent installations, working load is limited to 50% f_{pu} . Therefore, a test load of up to 150% of the working load is used. Habib (1989) suggests other testing loads in his Chapter 5.

Anchors undergoing testing may fail. Three main causes of failure are breakage of the tendon, relaxation of the prestress and overloading above the design load value. Breakage is normally the result of corrosion (Section 2.1.3.2.3) but contamination of the tendon (such as by weld splatter) and eccentricity of the load caused by improper anchor head design may also result in failure. Relaxation of the prestress may result from yield of the fixed anchor, ground consolidation, overestimation of the anchor working load, load redistribution in a cluster of anchors (i.e., after one anchor fails), or breakage of a wire in a strand tendon. Loading beyond the design load most often results from redistribution of loads in a cluster of anchors, forward movement of a retaining wall, swelling soil, and ground movements such as those resulting from displacements along joints or drying of the soil.

2.2.1.6.2 Precontract Tests

Precontract tests serve to confirm that a particular type of anchor will perform adequately for a given job in a given location. In addition, precontract tests provide data on the performance of individual components of the anchor system such as the tendons and anchor heads. They should be mandatory at sites where there is no previous construction experience, where unusually long anchors are required, and where difficulties in drilling and grouting are expected. It is also very important that the anchors which have undergone these tests *never* be used in any installations. Precontract are often conducted at loads near or including failure which compromises the structural integrity of the anchor.

These tests should be performed before any service anchors are manufactured since the primary purpose of the precontract testing is to confirm the proposed design. Sufficient time should be allowed prior to initiation of construction for precontract tests to be performed. These tests may take several weeks as they must be installed, grout must harden, and testing instrumentation must be installed and calibrated. The test anchors should be located on-site in locations which are as representative of final conditions as possible. The construction methods for the test anchors should be nearly identical to those to be used for permanent installation, especially in regard to drilling methods and anchor hole diameters, length and depth of the fixed zone, and prefabrication, homing, and grouting methods.

The primary purpose is to test the grout bonds. Hence, the area of steel used in the tendon may be increased to insure that the failure occurs in the grout and not in the tendon.

Xanthakos (1991) recommends that for permanent installations, two or three test anchors should be loaded to twice the design load and then to failure. (Habib 1989 recommends loading

only to a load equal to the factor of safety times the design load.) If feasible, the anchor should be excavated and examined, with particular attention paid to the condition of the fixed length, where and how the failure occurred in the fixed length, and the state of the corrosion protection. Xanthakos (1991) details a testing procedure for the precontract tests in his Chapter 7.

2.2.1.6.3 On-Site Suitability Tests

On-site suitability tests are used to insure that production, as-built anchors will perform adequately in the particular conditions of the construction site. These tests serve as a final check on installation procedures and design before major installation of the final anchors occurs. Unlike anchors which have undergone precontract testing, anchors which have had suitability testing may be used as support in the final construction. Detailed information regarding loading and extension is obtained during the test, and this is compared to results predicted during design.

The anchors to be tested are constructed in exactly the same manner as the service anchors. Two or more of the anchors in recognizable ground are chosen to undergo on-site suitability tests, which are monitored by a specialist team. The decision to specify on-site suitability testing is made based on the magnitude of the contract, variability of ground conditions, anchor load capacity, and previous experience with anchor construction in similar site conditions.

2.2.1.6.4 Acceptance (Proof) Tests

Acceptance tests, also called proof tests, are performed on each anchor after final installation is complete to guarantee that each anchor is capable of safely supporting its design load. Testing is necessary because variations in soil conditions and anchor installation procedures may cause wide variations in anchor capacities.

A typical procedure is to load the anchor to 150% of the working load for a short time to verify the factor of safety. A load-extension diagram produced from data obtained during the proof test provides valuable information regarding the behavior of the anchor under load. Finally, the acceptance test proves that the lock-off load is stable.

2.2.1.6.5 Creep

Creep is the tendency of a material to elongate even under a constant load which is less than the elastic limit. A tendon may experience creep as may the soil in which the anchor is secured.

There are several procedures for testing for creep of a ground anchor. Xanthakos (1991) references a draft version of a Czechoslovakian standard. It states that a load of 1.2 times the service load be applied for temporary anchors, with a larger (but unspecified) load applied to permanent installations. The permanent elongation of the tendon should not be greater than 10% of the elongation experienced in the basic anchor test for the same load. Maximum displacement should be 0.135 mm/m (0.000135 in/in) of free anchor length for every tenfold increase in time. A standard of the French Bureau Securitas suggests that the initial residual load at lock-off be held for 72 hours. If elongation is more than 1 mm (0.04 in), creep may be a problem.

No matter the particular standard followed, the basic procedure is to maintain a constant stress, measure elongation with time, and then determine if the creep is within acceptable limits.

2.2.1.6.6 Testing Program

Since standards and practices for performing the above tests vary widely, no specific testing programs will be provided. Methods differ primarily in the stressing procedures and duration as

well as the number of tests required. The codes agree on one fact: anchors should be tested a load higher than the design load.

Even though no specific program will be given, a few general objectives will be given which may serve as a guide to developing a testing program for a specific site. First, theoretical load-extension diagrams should be prepared. These may then be compared to the actual data gathered in the test.

Results from the four basic test types may be compared to theoretical load diagrams. Precontract tests provide basic design parameters and may prompt a reevaluation of initial theoretical assumptions. Acceptance tests serve to prove (or disprove) precontract tests and are a means of insuring that the constructed anchors are capable of carrying the design load. On-site suitability tests provide additional data and insight into loaded anchor behavior with regards to load and extension performance over time. Finally, creep test results allow a determination of potential load loss due to ground or grout creep.

2.2.2 Wall Facing Installation Concerns

Several factors should be considered when installing the wall facing. Most importantly, the wall facing must be feasible and economical to install at the particular site and must adequately resist construction damage. Curing conditions must be considered if the wall is constructed of concrete on site. For a driven pile wall, the ground must be free of obstructions which could impede driving. In addition, piles must be transported to the site. This may be difficult if the piles are long.

The presence of groundwater produces additional problems. The additional water behind the wall exerts extra pressure on the wall. If a leak develops, it may cause dramatic failure as water washes the soil out from behind the wall. A leak may also cause a depression of the water table and leads to the settlement of structures on the high side of the wall. Plugging the leak can be hazardous and expensive. Dewatering on the low side of wall is expensive and may cause settlement if not done correctly. Disposal of dewatered water may be a minor problem. Moisture may effect the wall facing, particularly if the wall is constructed of cast-in-place concrete. Finally, drilling the anchor boreholes while preventing water from escaping is difficult.

2.3 Monitoring

Provisions should be made for the monitoring of anchored walls after construction is completed. One purpose of monitoring is to provided data on actual performance that may be compared with the theoretical predictions made during the design stage. Another more important purpose is to detect potential problems which may lead to failure of the anchored system and to take appropriate action. This allows an evaluation to be made of the design techniques so that they may be improved in subsequent designs.

This section will provide a general overview of monitoring methods for anchored systems. The first section will discuss monitoring of the anchors for loss of load, pore water pressure, and total earth pressure. The second section contains information regarding monitoring of the wall for

physical condition and movement. Excellent references for details on the instruments used to monitor wall movement are Hanna (1973) and Dunnycliff (1988).

2.3.1 Anchors

Monitoring of anchors involves making field measurements of load, movement, and pressure or stress (total or effective) as a function of time. Field measurements are naturally difficult to obtain since they must be made in a complex and dangerous environment: the site. Things to consider when planning monitoring activities are ground conditions, the structure to be monitored, the time frame in which measurements must be made, environmental conditions in which the instruments will be installed, the control which will exist on the site (Hanna 1982). Finally, these data must be interpreted to yield the desired information. Adequate training of personnel is essential since personnel errors are the most common cause of problems. Hanna (1982) provides a checklist of general considerations for field monitoring (p514).

Typical measurements which may be made are load measurement, total earth pressures, and pore water pressures (used to find effective stress). Load measurement is designed to measure the load in the anchor and is usually accomplished by a load cell placed between the wall and the bearing plate. Total earth pressure is difficult to measure because the presence of the cell modifies the stresses in the soil surrounding the cell. Pore water pressures must be measured, and this requires the use of piezometers. Effective stress in the soil determines its behavior. These measurements may be combined with others to measure long term creep.

2.3.1.1 Load Monitoring

An important indicator of anchored wall performance is the loss of prestress in the tendons. Loss of load may cause unacceptable movement of the wall or may even lead to failure.

Several things may cause anchors to lose stress. Relaxation of steel and creep of both soil and grout are two factors which have been discussed previously. If the anchor is secured in rock, the stress from the anchor may cause compression of joints and fissures in the rock. Shocks applied to the ground (from blasting or earthquakes, for example) may cause anchors to lose stress due to densification of the ground. Finally, variable loading of the anchor and changes in temperature and stress of the anchoring medium may lead to load loss.

Various methods may be employed to monitor loss of prestress. Perhaps the simplest is to attach a jacking mechanism to the tendon and apply sufficient force until the tendon just clears the bearing plate. Load in the tendon may be measured as during the initial prestressing.

If the anchor head assembly is not accessible, loads are usually measured by means of a load cell. In this case, the load cell must be stiff, the load must be centrally applied to it, and the instrument must be protected from the environment. Four considerations in choosing a load cell are cost, the environment in which it will be used, and the nature of the load to be measured and the accuracy required.

Load cells are classified according to how they operate. Mechanical load cells use physical deformation of materials and a dial gage to monitor loads. These cells may be mounted between two permanent locations on a wall such as between two bolts. An example is a disc load cell is shown in Figure 25. A similar method is the indirect method, in which deformation of a strut or beam is measured and analyzed using the known strength properties of the material (Hanna 1973).

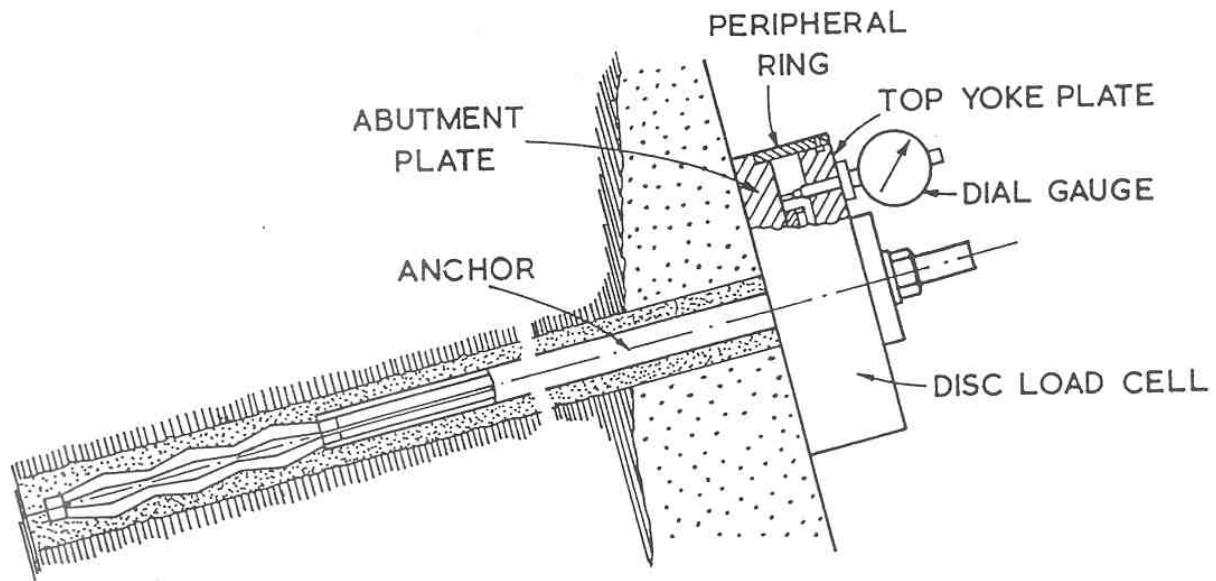


Figure 25. Schematic view of load disc cell (from Hanna 1973)

Photoelastic load indicators operate by the deformation of a glass or polymeric cylinder. This deformation produces fringe patterns which may be viewed under polarized light to quantify loads.

Strain-gagged load cells utilize the basic principle that a metal's electrical resistance varies directly with deformation. Strain gages are mounted to a carefully machined metal surface, and loads are determined by the change in resistance measured by the amount of electrical current passing through the strain gage.

Vibrating wire load cells employ a stretched wire. As the tension in the wire changes, the frequency at which it vibrates changes. If an oscillation is produced in the wire, the change in natural frequency of the wire may be used to determine the load.

Another method of load measurement is the use of the fluid pressure in a hydraulic jack. Tension in a wire may be determined by use of a tension meter where the wire is locked at two points and is deflected at the middle point by a known force. One final method is a load alarm, such as the patented "RESPLAT." This mechanism employs a spring and sounds an alarm if the load fall below a preset level.

Frequency of reading and specific types of monitoring which are required are usually dictated by local codes. Habib (1989) suggests that monitoring be performed quarterly for the first year and yearly thereafter, and that 10% of the number of anchors between 1 and 50, 7% between 51 and 100, and 5% above 100 be tested. As another example, the British code recommends that loads in all anchors (permanent and temporary) be checked after 24 hours for load loss and creep. The same tests should be repeated weekly for one month, then monthly for three months for the first 10 anchors. Finally, tests should be performed on 5% of the anchors at 6 months and again at 12 months if all results are satisfactory after four months (Xanthakos 1991).

Anchor loads should be within $\pm 10\%$ of the working load. Figure 26 shows a typical anchored system and the location of instruments. This arrangement is recommended for walls which are more than 10 m (33 ft) deep and longer than 30 m (98 ft) in granular soils or 7 m (23 ft) long and 20 m (66 ft) long in cohesive soil, where rigidity is the determining factor of the analysis, where the water table on either side of the wall differs by more than 5 m (16 ft), where soil conditions are uncertain with respect to strength and modes of failure, and where movement or system failure will be detrimental to surrounding structures (Xanthakos 1991).

There are many factors to consider if the monitoring data indicate that restressing of the anchor is required. If possible, the restressing operation should be performed by the contractor who originally installed the anchor.

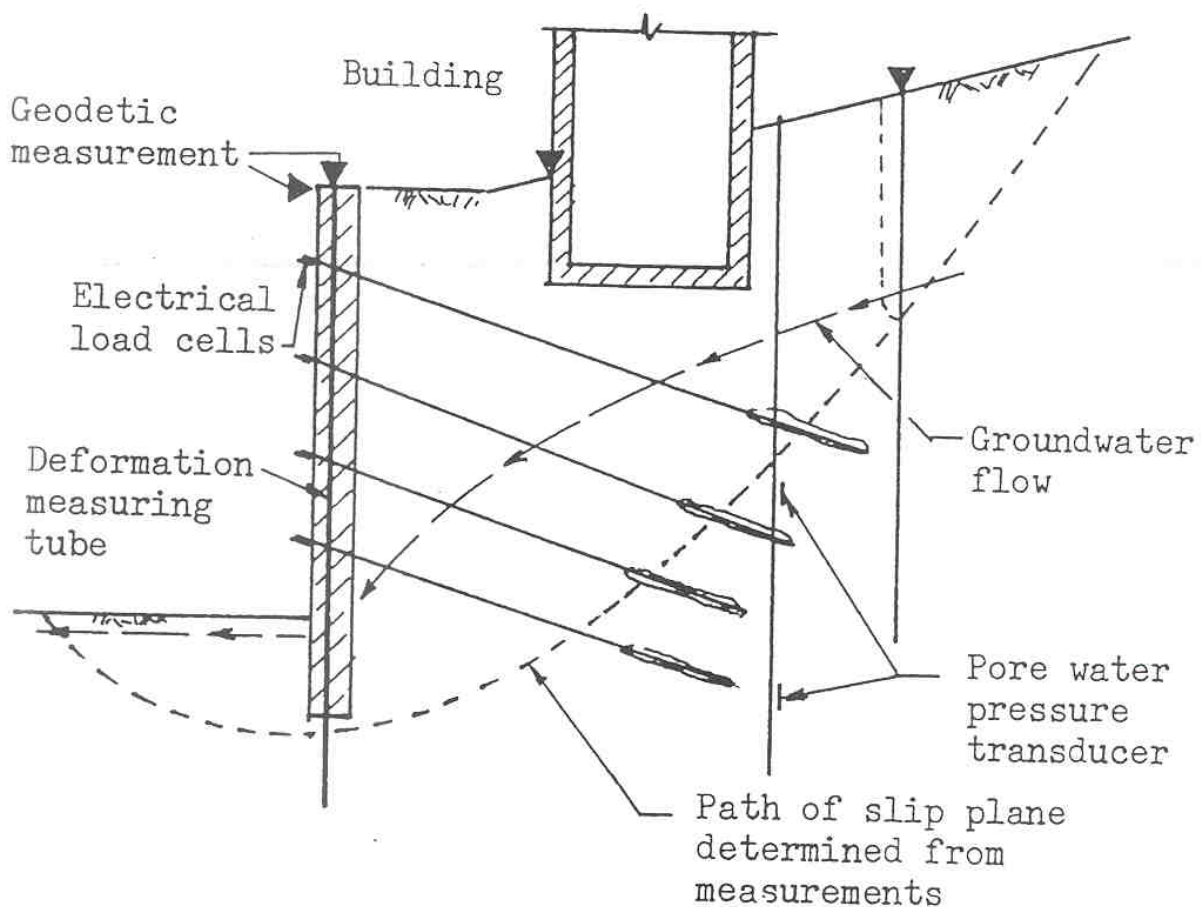


Figure 26. Monitoring systems for wall (from Xanthakos 1994)

2.3.1.2 Pore Water Pressure

Pore water pressure is an important determinant of soil behavior and is used to calculate the effective stress in a soil. The basic instrument used to measure pore water pressure is the piezometer. The basic operating principle is that a porous material is inserted into the ground. Water enters through a porous medium. The water pressure is then measured. A piezometer should be accurate, cause minimum interference to the soil it is inserted in, register changes in pore water pressure quickly, operate reliably over time, and be capable of recording continuously or intermittently (Hanna 1973).

There are several types of piezometers in use today. The most common is the open standpipe in which the water level in an open borehole is observed directly. A similar method is to install a casing in a borehole in which the lower portion has slots to allow water to enter. A porous tube piezometer utilizes a riser pipe of small diameter connected to a perforated casing with backfill surrounding the riser pipe. The use of a small diameter riser pipe reduces the equalization time.

Electrical piezometers operate on the principle that water pressure applied to one side of a diaphragm will cause a deformation of the diaphragm. This deflection may be used along with the known mechanical properties of the diaphragm material to calculate the pressure exerted by the water.

An air-pneumatic piezometer uses a similar principle, but air is used to exert pressure on the diaphragm. Water resists the deformation of the diaphragm, and the amount of movement and the known air pressure to move the diaphragm back may be used to calculate the water pressure. An oil pneumatic piezometer operates in the same fashion, but an oil is used instead of air.

2.3.1.3 Earth Pressures

To calculate effective stress, both pore water pressure and total earth pressure must be known. This section discusses methods for measuring the total earth pressure.

A major problem with measuring the total earth pressure is insuring that the load cell measures the average earth pressure. The fact that the load cell is of a different composition than the surrounding soil can result in erroneous readings as the presence of the load cell may cause increased or decreased stresses in the vicinity of the load cell.

There are several general types of load cells, each of which is typically designed to measure static or slowly changing earth pressures. Electrical earth pressure cells use the deflection of a diaphragm to calculate earth pressures. This deflection may be measured with strain gages or vibrating wire gages, both of which were described in the anchor monitoring section (Section 2.3.1).

Hydraulic cells typically contain pads with a large area-to-thickness ratio. Earth pressures on the pad change the pressure of fluid contained in the pad. This change in pressure is then measured by remote mechanical or electrical means.

A Carlsson stress meter utilizes a thin, pressurized film of mercury. Under pressure, the film causes a deflection in a diaphragm. The change is quantified by the change in output of a strain meter. The WES (U.S. Army Waterways Experiment Station) cell operates similarly except that four resistance strain gages are used to determine the results.

2.3.2 Wall Facing

As with anchors, walls should be inspected periodically for signs of physical distress. Specific areas of concern are corrosion of the wall, proper operation of the drainage systems, erosion at the toe, and movement of the wall. These topics will be addressed in this section.

2.3.2.1 Corrosion

If the wall facing is exposed, the wall should be inspected periodically for signs of corrosion. Indicators of possible corrosion include rust, bubbling of metal or paint, and discoloration or staining of the wall. Since the anchor head is the most common point of failure for anchored systems, careful inspection should be made in that area. Corrosion that penetrates the wall may cause loss of soil and water through the wall.

2.3.2.2 Drainage

Proper operation of the filter/drain system is crucial for proper wall performance. A buildup of water behind the wall causes large water pressures to act upon the wall. Since the wall was probably designed on the assumption that there would be no water pressure behind the wall, the design load of the wall may be exceeded.

It is important to inspect drains often to see that they are functioning properly. Drains which are dry after a heavy rain may be indicative of a clogging problem. Unclogging may be accomplished at least temporarily by backwashing the drain; however, this may damage the drainage system. Another method of coping with the problem is to install new drains from the front of the wall. Drainage problems may be alleviated by using methods which deter water from reaching the wall. Two of these methods are providing drainage swales at the top of wall and paving soil at top of wall to reduce infiltration.

2.3.2.3 Erosion at the Toe

Soil at the toe of the wall provides a passive earth force which acts to stabilize the wall. Erosion of soil at the toe may lessen this resisting force and cause movement and/or failure of the wall.

Toe erosion occurs when water is present external or internal to the wall. Potential causes include improper drainage design or malfunction, excessive water running over the top of the wall, clogging of a drainage swale at the base of the wall, or wave action. Furthermore, toe erosion may indicate that the filter/drain system has failed and is forcing the water to follow other paths through the wall. Erosion may be indicated by potholes or other depressions which open at the ground surface; these signal a loss of soil from behind the wall.

2.3.2.4 Movement of the Wall

One of the first indicators of potential trouble in an anchor system is movement of the wall. The wall may move in any of three dimensions, or it may bulge or bend at any point. Monitoring of the wall to detect such movement is the subject of this section.

2.3.2.4.1 On-site Methods

One of the quickest and simplest methods of monitoring for movement is by visual inspection. Any obvious tilting or bulging of the wall may signal the need for a closer investigation. Standard survey techniques may be used to changes in elevation of the wall or to detect movement. These surveys may include the use of lasers or photogrammetric methods where a series of pictures taken with accurately placed cameras may detect movement.

Vertical tube settlement gages use a string of telescoping tubes to which a series of plates are attached. Measurement of the settling of the plates yields data regarding the settlement of the ground at several elevations. For horizontal movement, a tensioned wire device may be used. In this method, wires under tension are placed behind the structure and are monitored in the same manner as the full profile gage method.

Inclinometers are a very common method of detecting and quantifying wall movement. A pendulum activated transducer is lowered down a near-vertical casing attached to the wall, and measurements of the tilt of the wall are made. These measurements may be compared with later readings to determine if movement has occurred.

The simplest type of inclinometer consists of a pipe attached to the wall. The length of straight steel rod which may be lowered through the provides a general idea regarding the amount of curvature of the wall. The rod will bind at locations of significant differential movement. More advanced methods include inclinometers which use pendulums whose measurements are recorded electrically or which use servo-accelerometers to calculation deviation from the vertical.

2.3.2.4.2 Remote Methods

Full profile gages consist of a cell unit, normally called a torpedo, which is pulled through a flexible pipe which runs horizontally or near horizontal underneath the wall. Changes in current passing through steel plates mounted above the pipe are detected by the cell in the torpedo, allowing movement of the wall to be detected.

Another method is the use of lasers. Lasers are aimed at targets mounted on the wall to detect movement using conventional surveying techniques.

3 Geology of Birmingham, AL

This section's purpose is to provide general information regarding the geology of Birmingham in Jefferson County, Alabama.. A brief overview of important characteristics of engineering geology related to the construction of tieback walls will be provided first. Then, specific information regarding the geology of the Birmingham metropolitan area will be given.

3.1 General Considerations

Most general geologic investigations are performed in relation to construction and/or mining in an area. Factors to consider are drainage, excavation difficulties, strength of soil and/or rock, shrink-swell potential, permeability, and slope stability. Most of these general factors are of interest for the construction of tieback walls.

An ideal site for construction in the Birmingham area would have a moderately thick soil layer overlying even bedrock. The soil should would exhibit low shrink-swell potential, fair to good drainage characteristics and infiltration rates, a good load bearing capacity, and slope stability up to 40°. The site should not be susceptible to flooding or intermittent swampy conditions and should not be adjacent to any steep man-made or natural slopes (Szabo 1981).

3.2 Site Conditions

Sites which meet all of the listed criteria for an "ideal" site are very rare in the Birmingham area. How well metropolitan Birmingham meets these criteria will now be discussed considering standing water, flooding, excavation difficulty, earthquakes, surface subsidence, and soil and bedrock conditions.

3.2.1 Flooding

Standing water is typically a problem in Birmingham only after heavy rain. One small portion of eastern Birmingham does experience standing water after only a light rain. A few locations in central Birmingham are located in a 100-year flood plain as well. Nearly all of the city has a fair infiltration rate of 1.5 to 2.4 minutes per mm (40 to 60 minutes per inch). Small sections in the east have a good infiltration rate of 0.4 to 1.5 minutes per mm (10 to 40 minutes per inch), while a tiny portion of central Birmingham experiences a poor infiltration rate of less than 0.4 or more than 2.4 minutes per mm (less than 10 or greater than 60 minutes per inch). These conditions may lead to a high water table; therefore, corrosion protection and drainage systems should be designed accordingly.

3.2.2 Soil and Rock Characteristics

Nearly all of Birmingham has an irregular bedrock surface underlying the soil which may require blasting for excavation for depths greater than 20 feet. Some small portions will almost definitely require blasting for depths greater than 20 feet, while other small sections may typically be excavated with general construction equipment. Pinnacle limestone formations are common subsurface bedrock formations in Jefferson County. These irregular, pointed formations make excavation difficult because they form a mixture of hard rock and soil at the same elevation.

Bearing capacity is highly variable in the city, ranging from less than 0.3 MPa (3 tsf) to greater than 0.6 MPa (6 tsf). Swell potential risk is generally moderate, but portions of the city experience both low and high potential.

Slopes in most areas are stable up to 30°, with some sections being stable up to 40°. A small section in central Birmingham experiences unstable slopes in any conditions which are not natural cuts. Vertical cuts over 3 m (10 ft) high are stable in most locations, but vertical cuts in a section in central Birmingham are only stable up to 3 m (10 ft). Vertical cuts in a narrow strip in eastern Birmingham are unstable if they are greater than 1.5 m (5 ft). (Szabo 1981)

3.2.3 Earthquakes and Sinkholes

Birmingham is approximately evenly split between areas of relatively stable slopes and areas in which steep natural slopes and man-made slopes may be unstable. There is a narrow strip of eastern Birmingham in which there is a high risk of damage from earthquakes. Only one confirmed and four suspected earthquakes have been recorded in all of Jefferson County. Only minor damage was reported. Nevertheless, the county is in a zone with a potential for moderate damage according to the "Seismic Risk Map of the United States" of 1969. Damage is especially likely in areas near or on steep slopes, faults, and areas of man-made fill as earthquakes may initiate movement in these areas (Szabo 1981).

Sinkholes resulting from limestone or dolomite bedrock are likely in most of Birmingham. Southwestern sections may be at risk for surface subsidence from mines, while a strip in western Birmingham has little risk from either sinkholes or surface subsidence. USGS topographic maps indicate many sinkholes in Jefferson County.

3.3 Rock Formations in Birmingham

Birmingham is situated in the Alabama Valley and Ridge geologic province. The major rock formations which are located in metro Birmingham are the Knox group undifferentiated and the Ketona Dolomite.

3.3.1 Knox Group Undifferentiated

The Knox group is primarily composed of cherty dolomite and is estimated to be up to 610 m (2,000 feet) thick. The residual soil is typically a cherty clay (AASHTO classification of A-2 to A-4) as thick as 0.6 m (2 ft) and a dense clay (AASHTO classification of A-4 to A-6) of approximately 0.3 m (1 ft) thick along with scattered chert pebbles and boulders up to 0.6 m (2 ft) in diameter.

The soil is quite porous and this, along with solution openings in the bedrock, result in fairly good drainage and few flooding problems. Infiltration rates of the cherty clay is 0.4 to 1.2 minutes per mm (10 to 30 minutes per inch) and 1.2 to 2.4 minutes per mm (30 to 60 minutes per inch) for the dense clay. The shrink-swell potential is 2 to 4 percent, and bearing capacity is 0.3 to 1.1 MPa (3 to 12 tons per square foot). The soil is generally stable on slopes up to 40°.

Bedrock has a highly irregular surface. Since the soil is thick (up to 30 m or 100 ft), bedrock is not usually encountered in excavations. However, when it is encountered, blasting is usually necessary. The bedrock has a high bearing capacity but is susceptible to solution cavities and fracturing.

3.3.2 Ketona Dolomite

The Ketona Dolomite formation has a maximum thickness of about 183 m (600 ft). The residual clayey soil may be up to 30 m (100 ft) thick and may have interspersed fragments and boulders of dolomite.

The soil (AASHTO classification of A-4 to A-6) typically has poor drainage and infiltration rates of 0.8 to 1.6 minutes per mm (20 to 40 minutes per inch). Standing water is common during heavy rains. The soil may even absorb water to the saturation point and become plastic. Cuts steeper than 30° are unstable. Portions of the Ketona Dolomite formation are difficult to excavate due to the large number of boulders and the irregular surface of the bedrock. Bearing capacity of the soil is in the range of 0.1 to 0.6 MPa (1 to 6 tons per square foot), and there is a moderate shrink-swell potential.

Bedrock is very stable and will support vertical cuts in excess of 3 m (10 ft). Bearing capacity is 1.9 to 2.9 MPa (20 to 30 tons per square foot), and blasting is necessary for excavation. However, there is a large risk of sinkholes and solution cavities, and careful subsurface exploration must be made before civil works are undertaken.

References

- ASTM D1586-84 (1986) **Penetration Test and Split-Barrel Sampling of Soils**, Vol. 4.08, ASTM, Philadelphia, PA, p298 ff
- Bang, S., Shen, C.K, Kim, K., Krotech, P. (1992) "Investigation of Soil Nailing Systems" in *Advances in Geotechnical Engineering*, Transportation Research Record 1369, Transportation Research Board, Washington, D.C., p37-43.
- Bowles, J.E. (1988) **Foundation Analysis and Design**, McGraw-Hill, NY.
- Hanna, T.H. (1973). *Foundation Instrumentation*. Vol. 1, No. 3 of Series on Rock and Soil Mechanics. TransTech Publications, USA.
- Hanna, T.H. (1982). *Foundations in Tension--Ground Anchors*. Vol. 6 of Series on Rock and Soil Mechanics. Trans Tech and McGraw-Hill, USA.
- Habib, P. (ed.) (1989). *Recommendations for the Design, Calculation, Construction and Monitoring of Ground Anchorages*. Trans. by A.A. Balkema. A.A. Balkema Publishers, Rotterdam.
- Hobst, Leos and Josef. Zajíc (1983). *Anchoring in Rock and Soil* (2nd Ed.). Volume 33 of *Developments in Geotechnical Engineering*. Trans. by Ing. Prokop Maxa. Elsevier Scientific Publishing, Czechoslovakia.
- Littlejohn, G.S. (1986). *Corrosion and Corrosion Protection of Prestressed Ground Anchorages*. G.S. Littlejohn, Chairman of Working Group on Corrosion and Corrosion Protection of Prestressed Ground Anchorages. Thomas Telford Ltd., London.
- Luetlich, S.M., Giroud, J.P., Bachus, R.D. (1992) "Geotextile Filter Design Guide" *Geotextiles and Geomembranes*, v11, p355-370
- Navy, U.S. (1982) "Soil Mechanics, Design Manual 7.1, Foundations and Earth Structures, Design Manual 7.2", U.S. Govt. Printing Office, Washington, D.C.
- PileBuck, Inc. (1990) *Sheetpile Wall Design Manual*, PileBuck, Inc, Jupiter, FL
- Schnabel, Harry Jr. (1982). *Tiebacks in Foundation Engineering and Construction*. McGraw-Hill, New York.
- Schnabel Foundation Company (1996). *Draft Final Report--Ground Anchor Walls: Research Results and Recommendations*. U.S. Department of Transportation, Federal Highway Administration. Contract # DTFH61-89-C-0038.
- Szabo, M.W. (1981). "Engineering Geology" chapter in *Atlas 17: Geology and Natural-Resource Factors Related to Planning and Government in the Jefferson County-Birmingham Area*. Geological Survey of Alabama, University, Alabama. pp. 47-52.
- Szabo, M.W. et al (1979). *Atlas 14: Engineering Geology of Jefferson County, Alabama*. Geological Survey of Alabama, University, Alabama. pp. 5-10.
- Terzaghi, K., Peck, R.B. (1967) **Soil Mechanics in Engineering Practice**, John Wiley, NY.
- Terzaghi, K., Peck, R.B, Mezri, G. (1996) **Soil Mechanics in Engineering Practice**, John Wiley, NY.
- Xanthakos, Petros P. (1991). *Ground Anchors and Anchored Structures*. John Wiley & Sons, New York.

Bibliography

- Burland, J.B. and Moore, J.F.A., (1973), "The Measurement of Ground Displacements Around Deep Excavations," Symposium, Field Instrumentation in Geotechnical Engineering, Butterworths, 70-84.
- Buro, M., (1972), "Rock Anchoring at Libby Dam," *West. Constr.* (March), 42, 48, 66.
- Chen, S.C. and McMullan, J.G., (1974), "Similkameen Pipeline Suspension Bridge," *ASCE, Transp. Eng. J.*, **100** (TEI, Feb.), 207-219.
- Cheney, J.E., (1973), "Techniques and Equipment Using the Surveyors Level for Accurate Measurement of Building Movement," Symposium, Field Instrumentation in Geotechnical Engineering, Butterworths, 85-99.
- Clayton, C.R.I. (1986), *Earth Pressure and Earth-Retaining Structures*, Surrey University Press, Glasgow
- Clough, G.W., (1973), "Performance of Tied-Back Walls," *Proceedings*, Conf. On Earth and Earth Supported Structures, ASCE, Purdue University, Vol. III, June, pp. 259-264.
- Clough, G.W., et al., (1972), "Design and Excavation of a Tied-Back Wall," *Proceedings*, Conf. On Earth and Earth Supported Structures, ASCE, Purdue University, Vol. I, Part 2, June, pp. 1367-1390.
- Clough, G.W. and Tsui, Y., (1994), "Performance of Tied-Back Walls in Clay," *J. GED*, ASCE, Vol. 100, No. GT12, December, pp. 1259-1273.
- Design and Performance of Earth Retaining Structures: Proceedings of a Conference* (1990), ASCE, New York.
- Gosschalk, E.M. and Taylor, R.W., (1970), "Strengthening of Muda Dam Foundation Using Cable Anchors," *Proc. 2nd Cong. Inst. Soc. Rock Mech.* Belgrade, 205-210.
- Irwin, M.J., (1973), "Instruments Developed by the TRRL for Studying the Behaviour of Earthworks," Symposium, Field Instrumentation in Geotechnical Engineering, Butterworths, 194-206.
- Jones, C.J.F., (1973), "Field Measurements of Earth Pressures Against Motorway Retaining Walls and Bridge Abutments," Symposium, Field Instrumentation in Geotechnical Engineering, Butterworths, 207-219.
- Kennard, M.F., (1973), "Field Instrumentation Within a Civil Engineering Contract," Symposium, Field Instrumentation in Geotechnical Engineering, Butterworths, 220-228.
- Littlejohn, G.S. and Bruce, D.A., (1975), "Rock Anchors: State of the Art," *Ground Engineering*, May 1975, Vol. 8, No. 3, 25-32; July 1975, Vol. 8, No. 4, 41-48; September 1975, Vol. 8, No. 5, 34-45; November 1975, Vol. 8, No. 6, 36-45, March 1976, Vol. 9, No. 2, 20-29; May 1976, Vol. 9, No. 3, 55-60; July 1976, Vol. 9, No. 4, 33-44.
- MacLeod, J., and Hoadley, P.J., (1974), "Experience with the Use of Ground Anchors," *Proc. Tech. Session on Prestr. Concrete Found. and Ground Anchors*, 7th FIP Cong., New York, 83-85.
- Mitchell, J.M., (1974), "Some Experiences with Ground Anchors in London," *ICE Conf. on Diaphragm Walls & Anchors*, Lond., Paper No. 17, Sept.
- Monsur, C.I. and Alizadeh, (1970), "Tie-Backs in Clay to Support Sheeted Excavations," *J. SMFD*, ASCE, Vol 96, No. SM2, March, pp. 495-509.
- Morris, S.S. and Garrett, W.S., (1956), "The Raising and Strengthening of the Steenbras Dam (and Discussion)," *Proc. ICE*, Part 1, 5 (1), 23-55.

- Murphey, D.J., Clough, G.W., and Woolworth, R.S., (1975), "Temporary Excavation in Varied Clay,"
ASCE, J. GED, Vol. 101, No. GT3, March, pp. 279-295.
- Shannon, W.L. and Strazer, R.J., (1970), "Tied-Back Foundation Wall for Seattle First National Bank," Civil Engineering, ASCE, March.
- Skipp, B.O. and Marriott, M., (1973), "The Measurement and Interpretation of Ground Vibration,"
Symposium, Field Instrumentation in Geotechnical Engineering, Butterworths, 396-410.
- Standards Association of Australia, (1973), "Prestressed Concrete Code CA 35-1973," Section 5-
"Ground Anchorages," 50-53.
- Ware, K.R., Mirsky, M. and Leunity, W.E. (1973), "Tieback Wall Construction Results and
Controls," J. SMFD, ASCE, Vol. 99, No. SM12, Dec., pp. 1135-1152.
- Weatherby, D.E. (1982), Tiebacks, U.S. Department of Transportation, Federal Highway
Administration, Office of Research and Development, Springfield, Virginia.
- Xanthakos, S.E., (1974), "Underground Construction in Fluid Trenches," University of Illinois at
Chicago Circle, Chicago, Ill., April.

ASTM Specifications for Steel Tendons

A370-96 Mechanical Testing of Steel Products

A416/ A416M-96 Steel Strand, Uncoated Seven-Wire for Prestressed Concrete Adhesive-Bonded Anchors

A421-91 Uncoated Stress-Relieved Steel Wire for Prestressed Concrete

A882 / A882M - 92 Epoxy-Coated Seven-Wire Prestressing Steel Strand

C1019 - 89a Sampling and Testing Grout

D4435-84(1989)e1 Rock Bolt Anchor Pull Test

D4436-84(1994)e1 Rock Bolt Long-Term Load Retention Test

E1512-93 Testing Bond Performance of Adhesive-Bonded Anchors